

# HD800

## Compact Universal Heavy Duty Pulling Head for the G800 riveter

**INSTRUCTION SHEET**, Page 1 of 2

### DIMENSIONAL DATA (see Fig. 1)

- Weight- 0.2 Lbs.

### Choice of Riveters

- Use with the G-800 hand riveter

### Fasteners installed

- See Table 1 below.

Fig 1. Dimensional Data

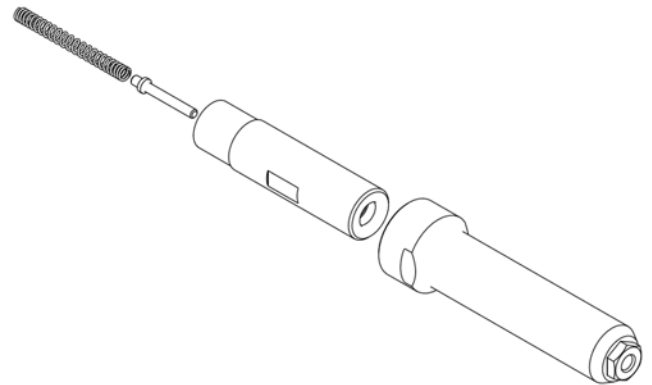
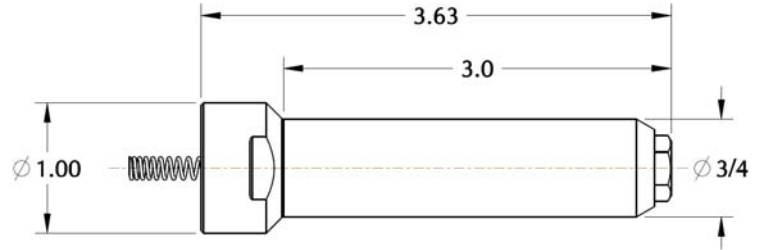

### MOUNTING INSTRUCTIONS (see Fig 2)

- Depress the pressure release button of the riveter and make sure the piston is fully returned.
- Place the stem stop & spring inside of the riveter piston; pay attention to the orientation of the stem stop
- Thread and tighten the collet assembly onto the riveter piston

### OPERATING INSTRUCTIONS

Prior to tool operation make sure that:

- Pulling Head is correctly mounted on the riveter and jaws are properly adjusted
- A proper nose-piece in good working condition is used.

TABLE 1  
Nose Piece and Jaw selection

MODEL NUMBER	JAW P/N	NOSE PIECE P/N	PULLING HEAD ASSEMBLY P/N	INSTALLS THE FOLLOWING PRODUCTS
	652-043	652-035	HD800-8	CherryMax, "AB" -8 (all materials), 8 Dia MB Plus
		652-024	HD800-8A	Cherrylock® "A" code
	865C25	652-035	HD800-8MB	Maxibolt-8 "S" type
		652-179	HD800-8MBU	Maxibolt-8 "U" type
	744C76	652-178	HD800-6MBU	Maxibolt-6 "U" type / "S" type AFS
		652-038	HD800-6MB	Maxibolt-6 "S" type Cherry

### During Operation:

- Inspect the active area of the nosepiece regularly.
- Keep the tool clean, especially the nosepiece and jaws; pay special attention when sealants and adhesives are used.
- If stem slippage occurs, clean or replace the jaws.



**CHERRY**®  
AEROSPACE

1224 East Warner Ave,  
Santa Ana, CA 92705  
Tel: 1-714-545-5511

www.cherryaerospace.com

# HD800

## Compact Universal Heavy Duty Pulling Head for the G800 riveter

INSTRUCTION SHEET, Page 2 of 2

### PARTS LIST

ITEM No	PART NUMBER	DESCRIPTION	QTY.
1	TABLE 1	Nosepiece	1
2	800-038	Sleeve	1
3	652-030	Collet	1
4	TABLE 1	Jaws	1 set
5	652-031	Jaw follower	1
6	P1425	Spring	1
7	800-039	Drawbar	1
8	753A15	Stem Stop	1
9	P-1483	Compression Spring	1

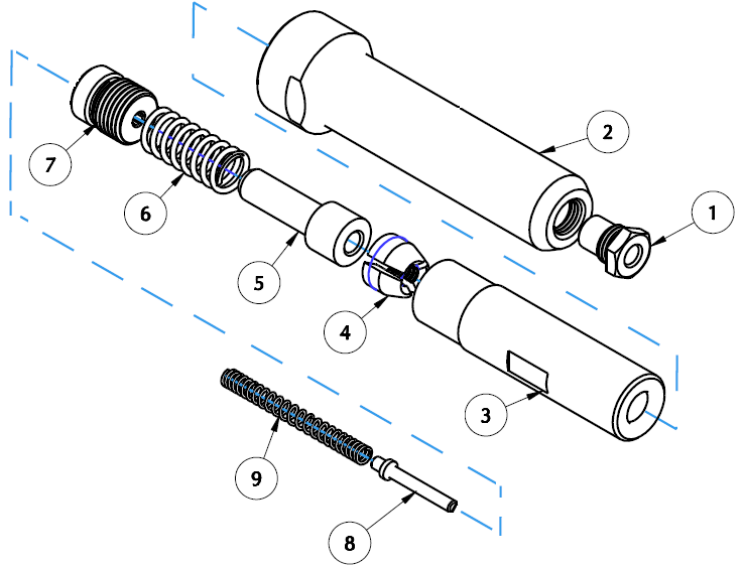

Replace items 1 and 4 in accordance with the fastener targeted to install; see "Table 1" for details

### PREVENTATIVE MAINTENANCE

- Clean and inspect the nosepiece, jaw and collet spring every 1000 installations or whenever a failure occurs; replace spring and jaws if worn.
- Lubricate outside configuration of the Jaws with Lubriplate® or similar light grease.
- Inspect regularly and keep active area clean and in good working condition.
- Replace worn or broken components.
- When re-assembling pay attention to the position and orientation of the Stem Stop (item 8).
- Use Loctite® 242 (removable) on all threaded components except as shown.

LOCTITE® is a registered trademark of Henkel Corporation.

LUBRIPLATE® is a registered trademark of Fiske Brothers Refining Co.

### WARRANTY

Seller warrants the goods conform to applicable specifications and drawings and will be manufactured and inspected according to generally accepted practices of companies manufacturing industrial or aerospace fasteners. In the event of any breach of the foregoing warranty, Buyer's sole remedy shall be to return defective goods (after receiving authorization from Seller) for replacement or refund of the purchase price, at the Seller's option. Seller agrees to any freight costs in connection with the return of any defective goods, but any costs relating to removal of the defective or nonconforming goods or installation of replacement goods shall be Buyer's responsibility. SELLER'S WARRANTY DOES NOT APPLY WHEN ANY PHYSICAL OR CHEMICAL CHANGE IN THE FORM OF THE PRODUCT IS MADE BY BUYER. THE FOREGOING EXPRESS WARRANTY AND REMEDY ARE EXCLUSIVE AND ARE IN LIEU OF ALL OTHER WARRANTIES AND REMEDIES; ANY IMPLIED WARRANTY AS TO QUALITY, FITNESS FOR PURPOSE, OR MERCHANTABILITY IS HEREBY SPECIFICALLY DISCLAIMED AND EXCLUDED BY SELLER. This warranty is void if seller is not notified in writing of any rejection of the goods within ninety (90) days after receipt of the goods by buyer.

Seller shall not be liable under any circumstances for incidental, special or consequential damages arising in whole or in part from any breach by Seller, AND SUCH INCIDENTAL, SPECIAL, OR CONSEQUENTIAL DAMAGES ARE HEREBY EXPRESSLY EXCLUDED.

Our policy is one of continuous development. Specifications shown in this document may be subject to changes introduced after publication.

NOTE: The properties, strength, dimensions, installed characteristics and all other information in these materials are for guidance only to aid in the correct selection of the products described herein and is not intended or implied as part of the above warranty. All applications should be evaluated for functional stability and available samples of the described parts can be requested for installed tests, suitability and evaluations.

For more information please contact our Technical Services Department at tel. 714-850-6022



**CHERRY**®  
AEROSPACE