

# H9044-8

## FOR CHERRYLOCK® “A” CODE RIVETS TECHNICAL DATA SHEET, Page 1 of 2

### DIMENSIONAL DATA

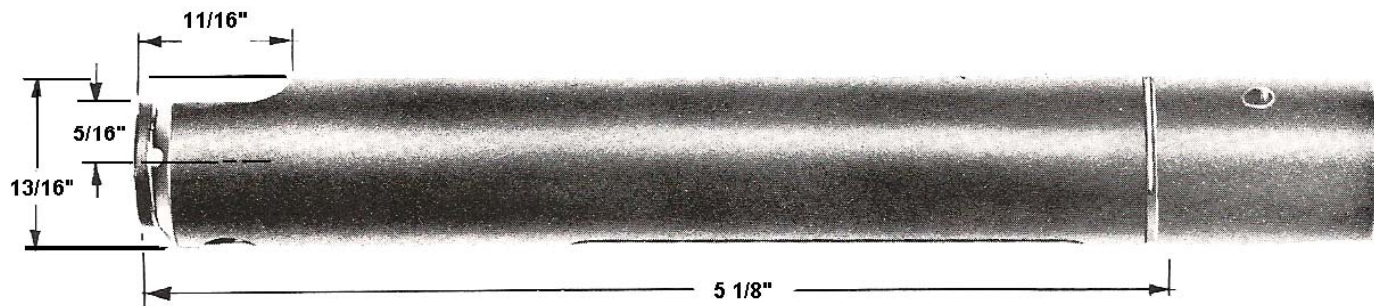

### CHOICE OF RIVETERS

- These heads fit directly on the G55, G86, both obsolete and G740 Cherry® power riveters.
- Will fit on the G784 and G689 hydro-shift Cherry® riveters with the 680B57 adapter.

### MOUNTING INSTRUCTIONS

- Attach riveter to air source for correct piston positioning.
- Make sure the jaws and all internal components of the collet are properly located.

### BEFORE USE, CHECK:

- The pulling head is correctly mounted.
- Proper air source is connected.
- The tool is clean and in good working condition.

### USAGE

- For the 1/4" CHERRYLOCK® “A” rivets.

### DURING OPERATION

- Inspect the active area of the nose piece regularly.
- Keep the tool clean, especially the nose piece and jaws; pay special attention when used with sealants and adhesives.
- If stem slippage occurs, the jaws need to be either cleaned or replaced.



**CHERRY®**  
AEROSPACE

# H9044-8

## FOR CHERRYLOCK® “A” CODE RIVETS

### TECHNICAL DATA SHEET, Page 2 of 2

#### PARTS LIST

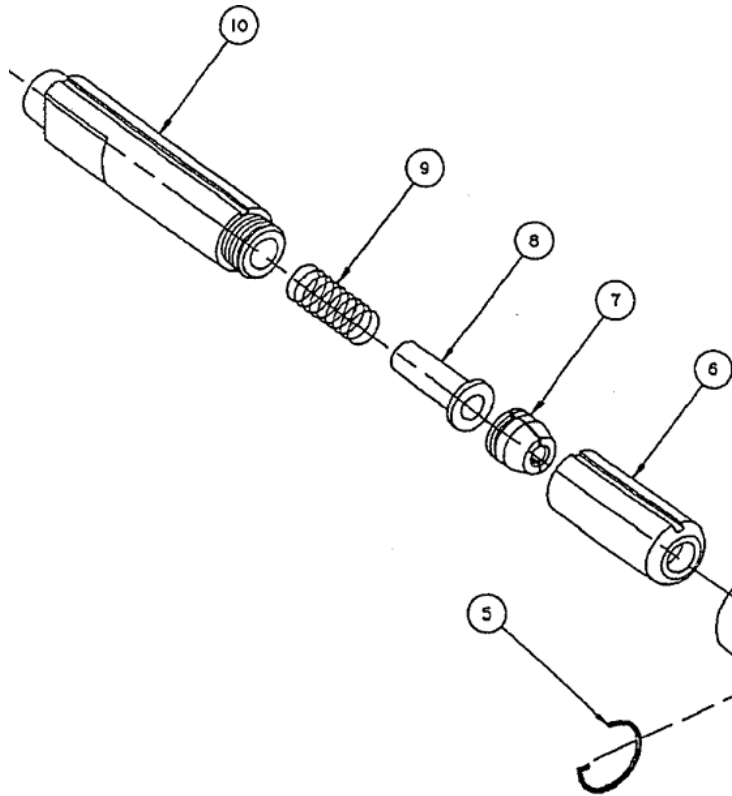

Item No.	Part No.	Description	Qty.
1	9044-012	Insert	1
2	711A9	Spring, Stem Stop	1
3	712A10-3	Stem Stop	2
4	9044-011	Sleeve	1
5	680A25	Spring	1
6	712B4	Collet	1
7	513-077	Jaws	1
8	712A7	Follower	1
9	712A8	Spring	1
10	712B5	Drawbolt	1

#### PREVENTATIVE MAINTENANCE

- Inspect active area regularly and keep it clean, in good condition
- Clean the jaws and jaw cavity inside the Collet every 1,000 installations.
- Lubricate outside configuration of the jaws with Lubriplate® or similar light grease.

Use Loctite® 242 (removable) on threaded components.

LOCTITE® is a registered trademark of Henkel Corporation.

LUBRIPLATE® is a registered trademark of Fiske Brothers Refining Co.

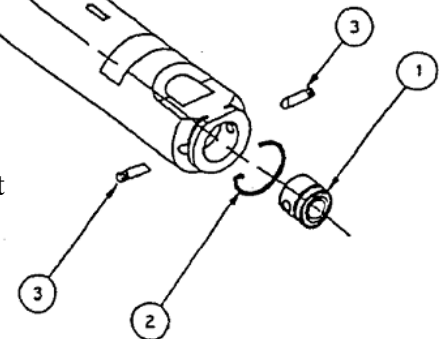

#### WARRANTY

Seller warrants the goods conform to applicable specifications and drawings and will be manufactured and inspected according to generally accepted practices of companies manufacturing industrial or aerospace fasteners. In the event of any breach of the foregoing warranty, Buyer's sole remedy shall be to return defective goods (after receiving authorization from Seller) for replacement or refund of the purchase price, at the Seller's option. Seller agrees to any freight costs in connection with the return of any defective goods, but any costs relating to removal of the defective or nonconforming goods or installation of replacement goods shall be Buyer's responsibility. SELLER'S WARRANTY DOES NOT APPLY WHEN ANY PHYSICAL OR CHEMICAL CHANGE IN THE FORM OF THE PRODUCT IS MADE BY BUYER. THE FOREGOING EXPRESS WARRANTY AND REMEDY ARE EXCLUSIVE AND ARE IN LIEU OF ALL OTHER WARRANTIES AND REMEDIES; ANY IMPLIED WARRANTY AS TO QUALITY, FITNESS FOR PURPOSE, OR MERCHANTABILITY IS HEREBY SPECIFICALLY DISCLAIMED AND EXCLUDED BY SELLER. This warranty is void if seller is not notified in writing of any rejection of the goods within ninety (90) days after receipt of the goods by buyer.

Seller shall not be liable under any circumstances for incidental, special or consequential damages arising in whole or in part from any breach by Seller, AND SUCH INCIDENTAL, SPECIAL, OR CONSEQUENTIAL DAMAGES ARE HEREBY EXPRESSLY EXCLUDED.

Our policy is one of continuous development. Specifications shown in this document may be subject to changes introduced after publication.

NOTE: The properties, strength, dimensions, installed characteristics and all other information in these materials are for guidance only to aid in the correct selection of the products described herein and is not intended or implied as part of the above warranty. All applications should be evaluated for functional stability and available samples of the described parts can be requested for installed tests, suitability and evaluations.

For more information please contact our Technical Services Department at tel. 714-850-6154



**CHERRY®**  
**AEROSPACE**