

H9040
FOR 9000 SERIES CHERRY® RIVETS
TECHNICAL DATA SHEET, Page 1 of 2

**CURRENTLY UNDER
CHANGE**

Contact Document Control for Status

DIMENSIONAL DATA

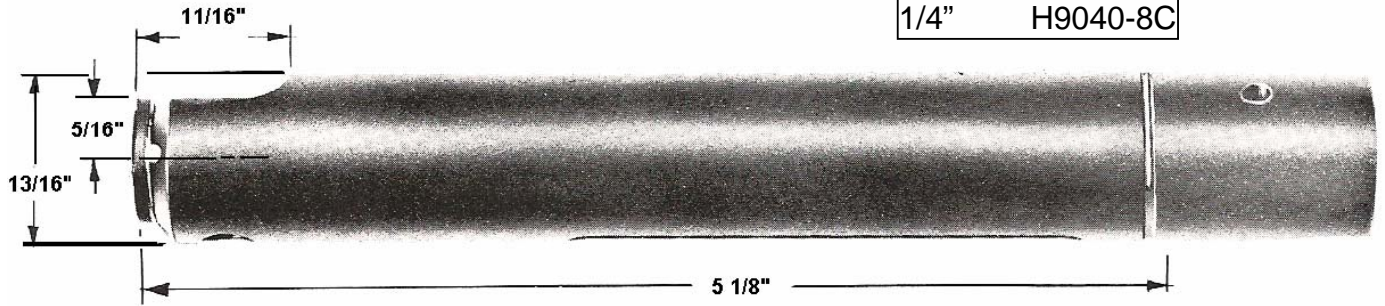

CHOICE OF RIVETERS

- These heads fit directly on the G740A Cherry® power riveter.
- Will fit on the CherryMAX® riveters (G704B, G746A and G747) with the 704A6 adapter.
- Will fit on G784 with the 680B57 adapter.

MOUNTING INSTRUCTIONS

- Attach riveter to air source for correct piston positioning.
- Make sure the jaws and all internal components of the collet are properly located; see parts list.

BEFORE USE, CHECK:

- The pulling head is correctly mounted and the proper riveter is selected.
- Proper air source is connected (see riveter specification for recommended pressure).
- The tool is clean and in good working condition.

USAGE

- 1/8", 5/32", 3/16" and 1/4" CHERRY® rivets, 9000 series.
- The countersunk version of the H9040 series will install both flush and universal head rivets.

DURING OPERATION

- Inspect the active area of the nose piece regularly.
- Keep the tool clean, especially the nose piece and jaws; pay special attention when used with sealants and adhesives.
- If stem slippage occurs, the jaws need to be either cleaned or replaced.



CHERRY®
AEROSPACE

H9040

FOR 9000 SERIES CHERRY® RIVETS

TECHNICAL DATA SHEET, Page 2 of 2

PARTS LIST

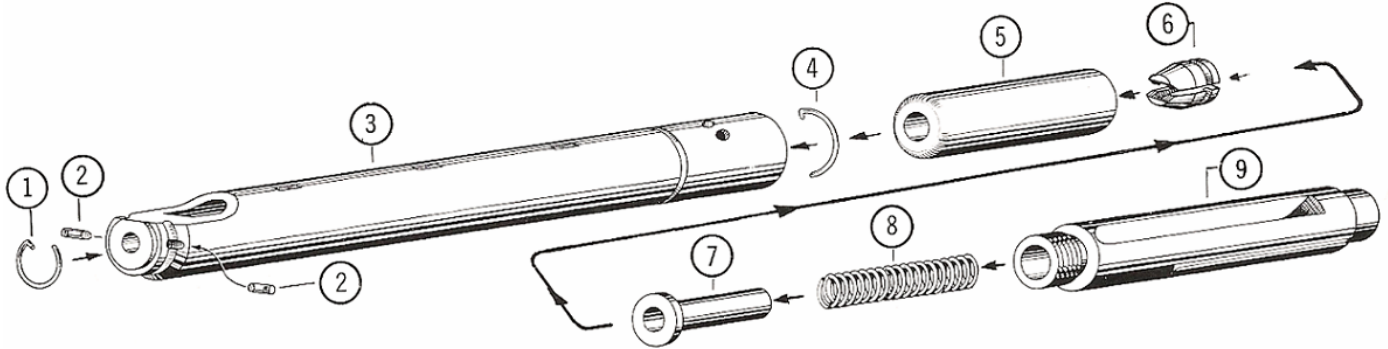

Ref. No.	Description	Qty Req.	H9040-4C	H9040-5C	H9040-6C	H9040-8C
1	SPRING, STEM STOP	1	711A9	711A9	711A9	711A9
2	STEM STOP	2	712A10-1	712A10-1	712A10-2	712A10-3
3	SLEEVE	1	712C2-4C	712C2-5C	712C2-6C	712C2-8C
4	SPRING, RETAINER	1	680A25	680A25	680A25	680A25
5	COLLET	1	712B4	712B4	712B4	712B4
6	JAW	1	712B6-4	712B6-5	712B6-6	712B6-8
7	JAW FOLLOWER	1	712A7	712A7	712A7	712A7
8	COMPRESSION SPRING	1	712A8	712A8	712A8	712A8
9	DRAWBOLT	1	712B5	712B5	712B5	712B5

PREVENTATIVE MAINTENANCE

- Clean the jaws and inside the Collet every 1,000 installations.
- Lubricate outside of the jaws with Lubriplate® or similar light grease.

LOCTITE® is a registered trademark of Henkel Corporation.

LUBRIPLATE® is a registered trademark of Fiske Brothers Refining Co.

WARRANTY

Seller warrants the goods conform to applicable specifications and drawings and will be manufactured and inspected according to generally accepted practices of companies manufacturing industrial or aerospace fasteners. In the event of any breach of the foregoing warranty, Buyer's sole remedy shall be to return defective goods (after receiving authorization from Seller) for replacement or refund of the purchase price, at the Seller's option. Seller agrees to any freight costs in connection with the return of any defective goods, but any costs relating to removal of the defective or nonconforming goods or installation of replacement goods shall be Buyer's responsibility. SELLER'S WARRANTY DOES NOT APPLY WHEN ANY PHYSICAL OR CHEMICAL CHANGE IN THE FORM OF THE PRODUCT IS MADE BY BUYER. THE FOREGOING EXPRESS WARRANTY AND REMEDY ARE EXCLUSIVE AND ARE IN LIEU OF ALL OTHER WARRANTIES AND REMEDIES; ANY IMPLIED WARRANTY AS TO QUALITY, FITNESS FOR PURPOSE, OR MERCHANTABILITY IS HEREBY SPECIFICALLY DISCLAIMED AND EXCLUDED BY SELLER. This warranty is void if seller is not notified in writing of any rejection of the goods within ninety (90) days after receipt of the goods by buyer.

Seller shall not be liable under any circumstances for incidental, special or consequential damages arising in whole or in part from any breach by Seller, AND SUCH INCIDENTAL, SPECIAL, OR CONSEQUENTIAL DAMAGES ARE HEREBY EXPRESSLY EXCLUDED.

Our policy is one of continuous development. Specifications shown in this document may be subject to changes introduced after publication.

NOTE: The properties, strength, dimensions, installed characteristics and all other information in these materials are for guidance only to aid in the correct selection of the products described herein and is not intended or implied as part of the above warranty. All applications should be evaluated for functional stability and available samples of the described parts can be requested for installed tests, suitability and evaluations.

For more information please contact our Technical Services Department at tel. 714-850-6022



CHERRY®
AEROSPACE