

H84A-8MBU

MAXIBOLT STRAIGHT PULLING HEAD, FOR -8 DIAMETER “U” TYPE MAXIBOLT® FASTENERS

Technical Data Sheet, Page 1 of 2

DIMENSIONAL DATA (all measurements in Inches, see figure 1)

Pulling Head Weight: 0.2 Lbs (0.09 kg)

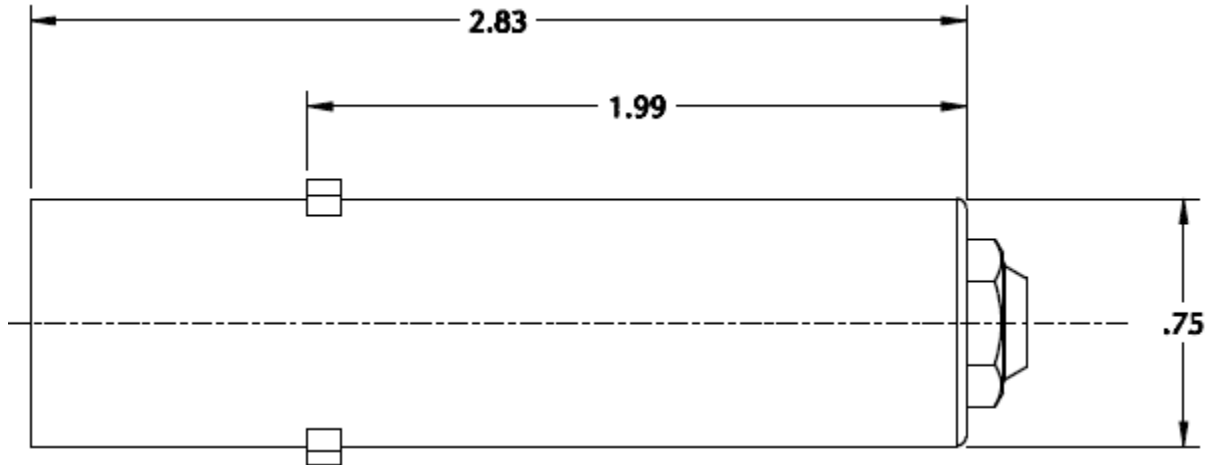

Figure 1

CHOICE OF RIVETERS

- **G84** Power Riveter
- **G84-LS** Split Power Riveter (with adaptor 744-700)

MOUNTING INSTRUCTIONS

- Attach riveter to air source for correct piston positioning.
- Thread Collet Assembly securely onto the riveter head piston.
- Depress the trigger and attach the sleeve assembly onto the bayonet mount.

USAGE

- Use for -8 diameter **Cherry** “U” type Maxibolt® and Huck™ (**ALCOA**) “U” and “S” Type Blind Bolts.

BEFORE USE, MAKE SURE THAT:

- Proper air source is connected (see riveter **manual** for recommended pressure).
- **Inspect the front end of the nosepiece to make sure that it is clean and in good working condition**

DURING OPERATION

- **Visually inspect** the active area of the nose piece regularly.
- Keep the nose piece and jaws clean, especially when sealants are used.
- If stem slippage occurs, **clean or replace the internal jaws**.



CHERRY®
AEROSPACE
SPS Fastener Division, a PCC Company

1224 East Warner Ave,
Santa Ana, CA 92705
Tel: 1-714-850-6022
www.cherryaerospace.com

H84A-8MBU

MAXIBOLT STRAIGHT PULLING HEAD, FOR -8 DIAMETER “U” TYPE MAXIBOLT® FASTENERS

Technical Data Sheet, Page 2 of 2

PREVENTATIVE MAINTENANCE

- Visually inspect the front end of the nosepiece as often as possible; due to the high installation shock, this area of the nosepiece is expected to have a shorter life span. Replace if damaged or worn. For greatly improved tool life, choose a Cherry “S” type Maxibolt® type fastener (shift washer type).
- Clean the nose piece, jaw set and collet every 1,000 installations, or when failures occurs.
- Lubricate outside configuration of the jaw set with Lubriplate® or similar light lubricant.
- Inspect regularly and keep the active area clean and in good working condition.
- Replace worn or broken components.

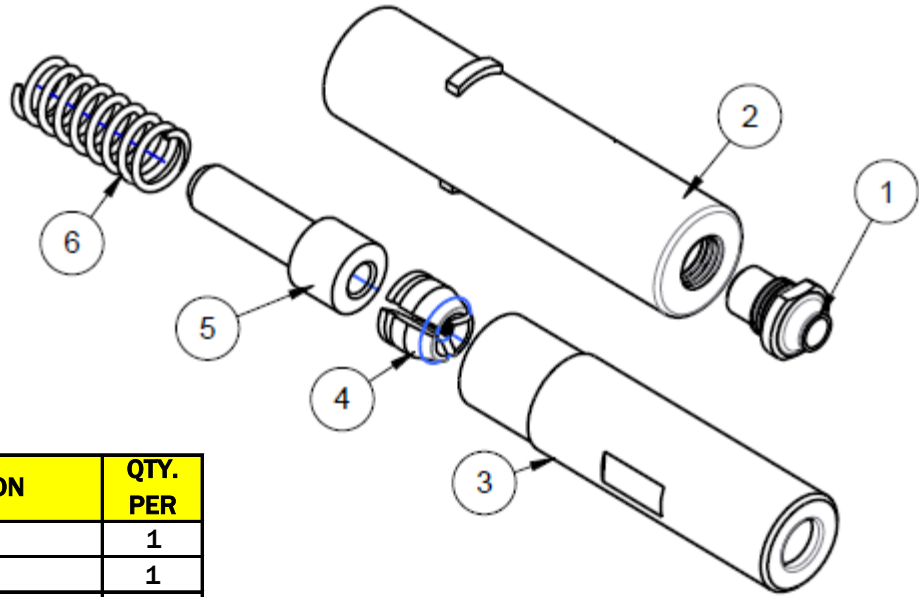

PARTS LIST

ITEM No.	PART NUMBER	DESCRIPTION	QTY. PER
1	652-179	NOSE PIECE	1
2	652-005	SLEEVE	1
3	652-030	COLLET	1
4	865C25	JAW SET	1
5	652-042	JAW FOLLOWER	1
6	P-1425	COMPRESSION SPRING	1

LOCTITE® is a registered trademark of Henkel Corporation.

LUBRIPLATE® is a registered trademark of Fiske Brothers Refining Co.

WARRANTY

Seller warrants the goods conform to applicable specifications and drawings and will be manufactured and inspected according to generally accepted practices of companies manufacturing industrial or aerospace fasteners. In the event of any breach of the foregoing warranty, Buyer's sole remedy shall be to return defective goods (after receiving authorization from Seller) for replacement or refund of the purchase price, at the Seller's option. Seller agrees to any freight costs in connection with the return of any defective goods, but any costs relating to removal of the defective or nonconforming goods or installation of replacement goods shall be Buyer's responsibility. SELLER'S WARRANTY DOES NOT APPLY WHEN ANY PHYSICAL OR CHEMICAL CHANGE IN THE FORM OF THE PRODUCT IS MADE BY BUYER. THE FOREGOING EXPRESS WARRANTY AND REMEDY ARE EXCLUSIVE AND ARE IN LIEU OF ALL OTHER WARRANTIES AND REMEDIES; ANY IMPLIED WARRANTY AS TO QUALITY, FITNESS FOR PURPOSE, OR MERCHANTABILITY IS HEREBY SPECIFICALLY DISCLAIMED AND EXCLUDED BY SELLER. This warranty is void if seller is not notified in writing of any rejection of the goods within ninety (90) days after receipt of the goods by buyer.

Seller shall not be liable under any circumstances for incidental, special or consequential damages arising in whole or in part from any breach by Seller, AND SUCH INCIDENTAL, SPECIAL, OR CONSEQUENTIAL DAMAGES ARE HEREBY EXPRESSLY EXCLUDED.

Our policy is one of continuous development. Specifications shown in this document may be subject to changes introduced after publication.

NOTE: The properties, strength, dimensions, installed characteristics and all other information in these materials are for guidance only to aid in the correct selection of the products described herein and is not intended or implied as part of the above warranty. All applications should be evaluated for functional stability and available samples of the described parts can be requested for installed tests, suitability and evaluations.

For more information please contact our Technical Services Department at tel. 714-850-6154



CHERRY®
AEROSPACE
SPS Fastener Division, a PCC Company

1224 East Warner Ave,
Santa Ana, CA 92705
Tel: 1-714-850-6022
www.cherryaerospace.com