

H846A-456

CherryMAX® Pulling Head

TECHNICAL DATA SHEET, Page 1 of 2

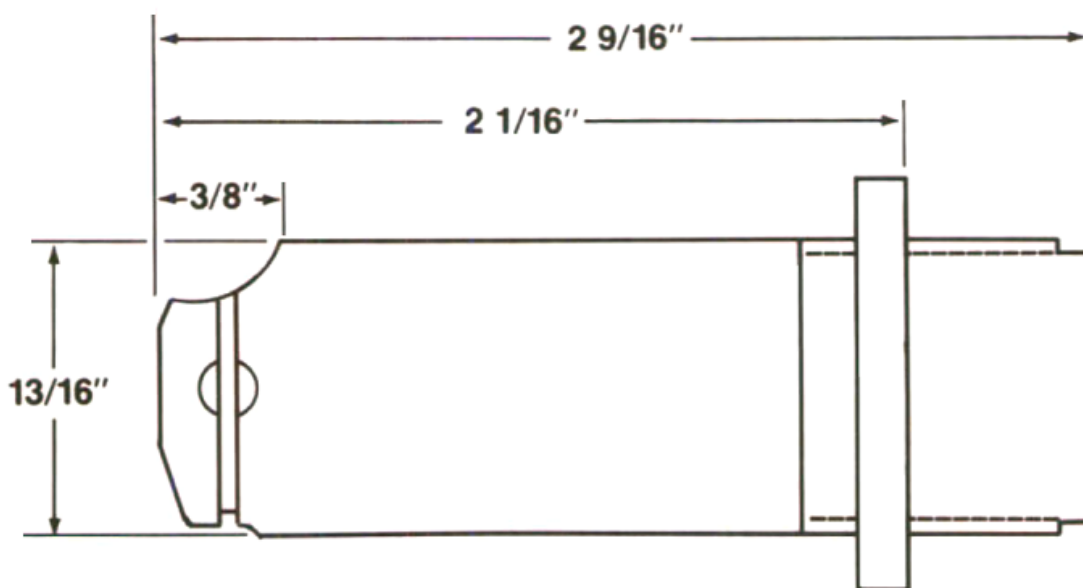

**This pulling head may fit directly on the G744 and G846 CherryMax® riveters.**

**It will install 1/8", 5/32" and 3/16" bulb & wiredraw CherryMax® rivets in all materials head styles and grip lengths.**



**CHERRY®**  
**AEROSPACE**

# H846A-456

## CherryMAX® Pulling Head

### TECHNICAL DATA SHEET, Page 2 of 2

#### INSTALLING H846A-456 PULLING HEAD ON RIVETER

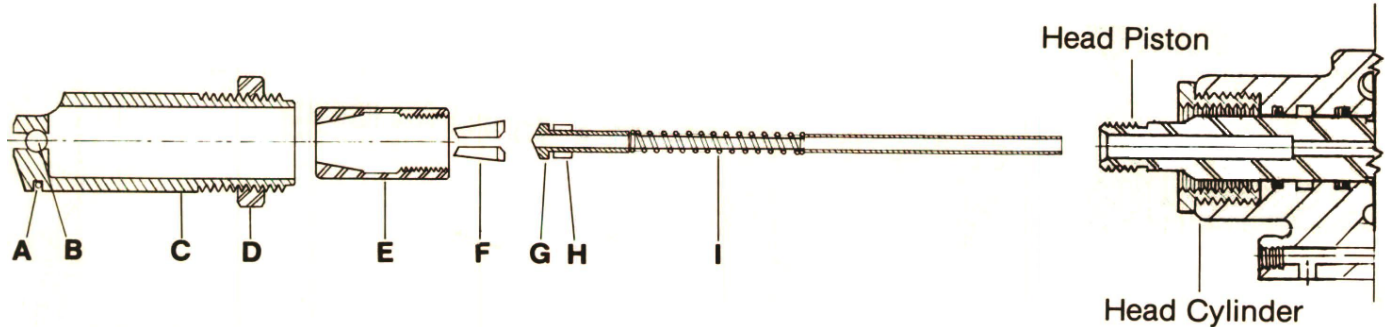

1. Place jaws (F) inside of the collet (E). Place bumper (H) and spring (I) over the jaw follower (G) and put this assembly inside collet against jaws.
2. Screw this assembly onto end of head piston and tighten securely using wrenches on flats provided. Use of Loctive #242 is recommended.
3. Thread outer sleeve (c) which contains jam nut (D) snugly into end of head cylinder. Tighten jam nut (D) securely.
4. Refer to parts list below for ordering replacement parts.

REF	Part No.	Description	Qty Req
A	701B25	Retaining Ring	1
B	701B24	Stem Stop	2
C	846B8	Sleeve	1
D	642A64	Jam Nut	1
E	846A12	Collet	1

REF	Part No.	Description	Qty Req
F	701B18	Jaws (pair)	1 set
G	846A23	Jaw Follower	1
H	846A15	Bumper	1
I	P964	Spring	1

#### MAINTENANCE AND REPAIR

Make sure that the pulling head is kept clean, especially around the riveting end, as adhesives, chips, sealants (etc...) will clog up the serrations of the jaws and may cause slippage of the stem.

#### WARRANTY

Seller warrants the goods conform to applicable specifications and drawings and will be manufactured and inspected according to generally accepted practices of companies manufacturing industrial or aerospace fasteners. In the event of any breach of the foregoing warranty, Buyer's sole remedy shall be to return defective goods (after receiving authorization from Seller) for replacement or refund of the purchase price, at the Seller's option. Seller agrees to any freight costs in connection with the return of any defective goods, but any costs relating to removal of the defective or nonconforming goods or installation of replacement goods shall be Buyer's responsibility. SELLER'S WARRANTY DOES NOT APPLY WHEN ANY PHYSICAL OR CHEMICAL CHANGE IN THE FORM OF THE PRODUCT IS MADE BY BUYER. THE FOREGOING EXPRESS WARRANTY AND REMEDY ARE EXCLUSIVE AND ARE IN LIEU OF ALL OTHER WARRANTIES AND REMEDIES; ANY IMPLIED WARRANTY AS TO QUALITY, FITNESS FOR PURPOSE, OR MERCHANTABILITY IS HEREBY SPECIFICALLY DISCLAIMED AND EXCLUDED BY SELLER. This warranty is void if seller is not notified in writing of any rejection of the goods within ninety (90) days after receipt of the goods by buyer. Seller shall not be liable under any circumstances for incidental, special or consequential damages arising in whole or in part from any breach by Seller, AND SUCH INCIDENTAL, SPECIAL, OR CONSEQUENTIAL DAMAGES ARE HEREBY EXPRESSLY EXCLUDED. Our policy is one of continuous development. Specifications shown in this document may be subject to changes introduced after publication. NOTE: The properties, strength, dimensions, installed characteristics and all other information in these materials are for guidance only to aid in the correct selection of the products described herein and is not intended or implied as part of the above warranty. All applications should be evaluated for functional stability and available samples of the described parts can be requested for installed tests, suitability and evaluations.

For more information please contact our Technical Services Department at tel. 714-850-6022



**CHERRY®**  
AEROSPACE