

H828-6MB

Right Angle Pulling Head for BlindBolt® (MaxiBolt®) fasteners

TECHNICAL DATA SHEET, Page 1 of 2

DIMENSIONAL DATA (all measurements in Inches, see Figure 1)

- Tool Weight (without riveter): 2.1 Lbs (0.9 Kg)

CHOICE OF RIVETERS

- **G744** Cherry Riveters (no adaptation necessary)
- **G83** or **G84** Riveters with Adapters P/N 744-200

ADAPTOR INSTRUCTIONS

- Remove the bayonet adapter from riveter (if present)
- Thread and tighten adapter 744-200 onto the Pulling Head

MOUNTING INSTRUCTIONS

- Attach riveter to air source for correct piston positioning.
- Push the drawbolt assembly forward (see Figure 1), before mounting
- While holding drawbolt in a forward position, thread the pulling head onto the riveter, making sure that both internal and external threads are connected.
- Use the jam-nut to lock the pulling head in position.
- Cycle the tool to make sure it is functional.

BEFORE USE, CHECK IF:

- The pulling head is correctly mounted and the proper riveter is selected.
- Proper air source is connected (see riveter specification for recommended pressure).
- The appropriate nose piece is used ("U" or "S" type – see component table).
- The tool is clean and in good working condition.
- The Jaws provide enough clearance for the Blindbolt® serrated area to fully engage in the tool freely; if the serrated stems get stuck inside of the jaws, the pulling head was mounted on the riveter incorrectly. See "Mounting Instructions".

USAGE

- This tool was designed to install "-6" diameter BlindBolt® (MaxiBolt®) fasteners.

DURING OPERATION

- Inspect the active area of the nosepiece regularly.
- Remove the broken stem by hand after each installation and dispose of them; if the broken stems get stuck, the Jaws do not open enough. Make sure the pulling head is correctly mounted.
- Keep the tool clean, especially the nosepiece and jaws; pay special attention when used with sealants and adhesives.
- If stem slippage occurs, the Jaws need to be either cleaned or replaced.

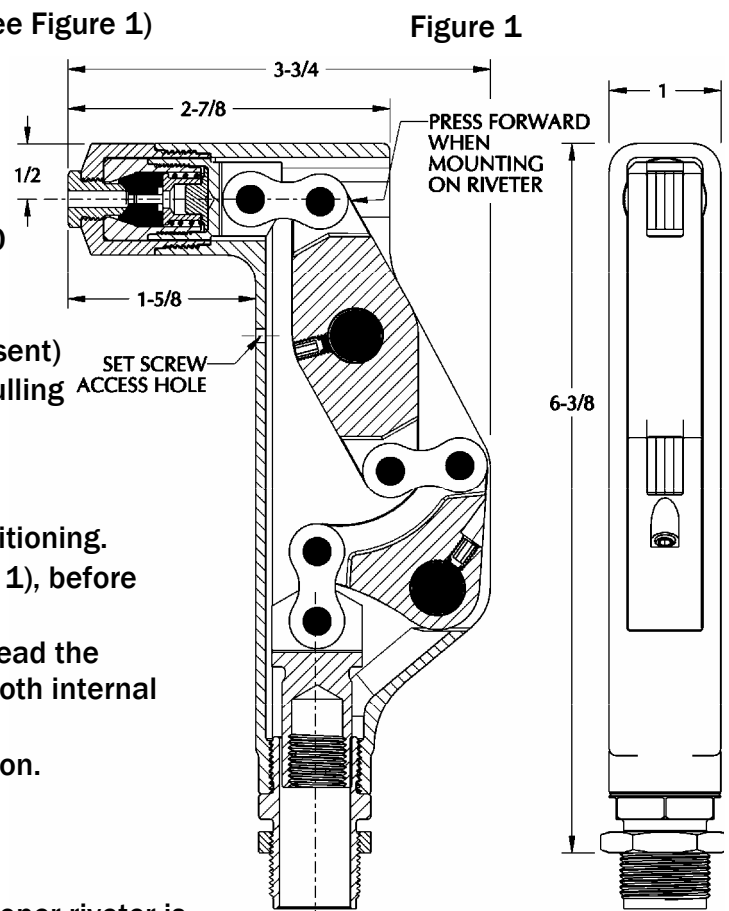

CHERRY®
AEROSPACE
SPS Fastener Division, a PCC Company

1224 East Warner Ave,
Santa Ana, Ca 92705
Tel: 1-714-545-5511

www.cherryaerospace.com

H828-6MB

Right Angle Pulling Head for BlindBolt® (MaxiBolt®) fasteners

TECHNICAL DATA SHEET, Page 2 of 2

PREVENTATIVE MAINTENANCE

- Inspect active area regularly and keep it clean, in good condition
- Clean the Insert, Jaws and Jaw Cavity inside the Collet every 1,000 installations.
- Lubricate outside configuration of the jaws with Lubriplate® or similar light grease.
- Use Loctite® 242 (removable) on threaded components as shown.
- At assembly, thread in the Set Screws tightly (ITEM 16), then back them off ¼ of a turn.

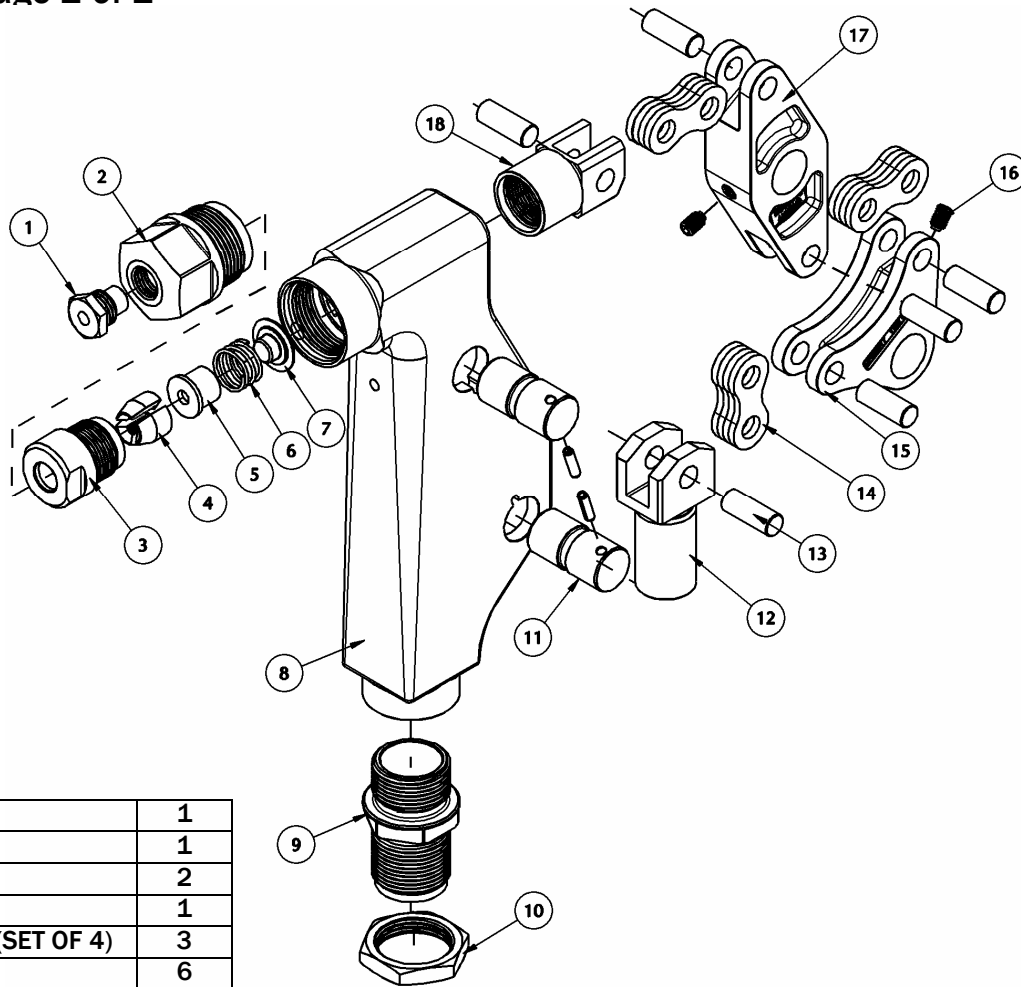

PARTS LIST

18	828B6	COLLET BOLT	1
17	828B3	LEVER	1
16	P-930	SET SCREW	2
15	828B4	BELL CRANK	1
14	828B15	LINK PLATES (SET OF 4)	3
13	828B14	LINK PIN	6
12	828B5	DRAWBOLT	1
11	828B13	PIVOT PIN ASSEMBLY	2
10	642A64	JAM NUT	1
9	828B7	ADAPTER FITTING	1
8	828B2	FRAME	1
7	828B11	GUIDE BUTTON	1
6	828A12	COMPRESSION SPRING	1
5	828B21	JAW FOLLOWER	1
4	744C76	JAWS (SET OF 3)	1
3	828C9	COLLET	1
2	828C8	SLEEVE	1
1	828-036	-6 NOSEPIECE "U" TYPE	1
	828B23	-6 NOSEPIECE "S" TYPE	1
ITEM NO.	PART NUMBER	DESCRIPTION	QTY. PER ASSY.

LOCTITE® is a registered trademark of Henkel Corporation.
LUBRIPLATE® is a registered trademark of Fiske Brothers Refining Co.

WARRANTY

Seller warrants the goods conform to applicable specifications and drawings and will be manufactured and inspected according to generally accepted practices of companies manufacturing industrial or aerospace fasteners. In the event of any breach of the foregoing warranty, Buyer's sole remedy shall be to return defective goods (after receiving authorization from Seller) for replacement or refund of the purchase price, at the Seller's option. Seller agrees to any freight costs in connection with the return of any defective goods, but any costs relating to removal of the defective or nonconforming goods or installation of replacement goods shall be Buyer's responsibility. SELLER'S WARRANTY DOES NOT APPLY WHEN ANY PHYSICAL OR CHEMICAL CHANGE IN THE FORM OF THE PRODUCT IS MADE BY BUYER. THE FOREGOING EXPRESS WARRANTY AND REMEDY ARE EXCLUSIVE AND ARE IN LIEU OF ALL OTHER WARRANTIES AND REMEDIES; ANY IMPLIED WARRANTY AS TO QUALITY, FITNESS FOR PURPOSE, OR MERCHANTABILITY IS HEREBY SPECIFICALLY DISCLAIMED AND EXCLUDED BY SELLER. This warranty is void if seller is not notified in writing of any rejection of the goods within ninety (90) days after receipt of the goods by buyer.

Seller shall not be liable under any circumstances for incidental, special or consequential damages arising in whole or in part from any breach by Seller, AND SUCH INCIDENTAL, SPECIAL, OR CONSEQUENTIAL DAMAGES ARE HEREBY EXPRESSLY EXCLUDED. Our policy is one of continuous development. Specifications shown in this document may be subject to changes introduced after publication.

NOTE: The properties, strength, dimensions, installed characteristics and all other information in these materials are for guidance only to aid in the correct selection of the products described herein and is not intended or implied as part of the above warranty. All applications should be evaluated for functional stability and available samples of the described parts can be requested for installed tests, suitability and evaluations.

For more information please contact our Technical Services Department at tel. 714-850-6022



CHERRY®
AEROSPACE
SPS Fastener Division, a PCC Company

1224 East Warner Ave,
Santa Ana, Ca 92705
Tel: 1-714-545-5511
www.cherryaerospace.com