

# H828-56MBP

## Right Angle Pulling Head for MaxiBolt® Plus fasteners

### TECHNICAL DATA SHEET, Page 1 of 2

#### DIMENSIONAL DATA (all measurements in Inches, see Figure 1)

- Tool weight (without riveter): 2.1 Lbs (0.9 Kg)

#### CHOICE OF RIVETERS

- G744 Cherry Riveters (no adaptation necessary)
- G83 or G84 Riveters with Adapters P/N 744-200

#### ADAPTOR INSTRUCTIONS

- Remove the bayonet mount (if present)
- Thread and tighten adapters 744-200 onto the pulling head

#### MOUNTING INSTRUCTIONS

- Attach riveter to air source
- Push the drawbolt assembly forward (see Figure 1)
- While holding drawbolt in a forward position, thread the pulling head onto the riveter, making sure that both internal and external threads are connected.
- Use jam-nut to lock the pulling head in position.
- Cycle the tool to make sure it is functional.

#### BEFORE USE, CHECK IF:

- The proper riveter is selected, the pulling head is correctly mounted, clean and in proper working condition.
- Proper air source is connected (see riveter specification for recommended pressure).
- The appropriate nose piece is used ("U" or "S" type – see component table).
- The jaws provide enough clearance for the BlindBolt® serrated area to fully engage in the tool freely;
  - If the pulling head is mounted incorrectly, the spent stems get stuck inside of the jaws.

#### USAGE

- -5 and -6 diameter MaxiBolt® Plus and EN BlindBolts® ; -5 BlindBolt® "S" type

#### DURING OPERATION

- Inspect the active area of the nosepiece regularly.
- Remove the broken stem by hand after each installation and dispose of them; if the broken stems get stuck, the jaws do not open enough. Make sure the pulling head is correctly mounted.
- Keep the tool clean, especially the nosepiece and jaws; pay special attention when used with sealants and adhesives.
- If stem slippage occurs, the jaws need to be either cleaned or replaced.

Figure 1

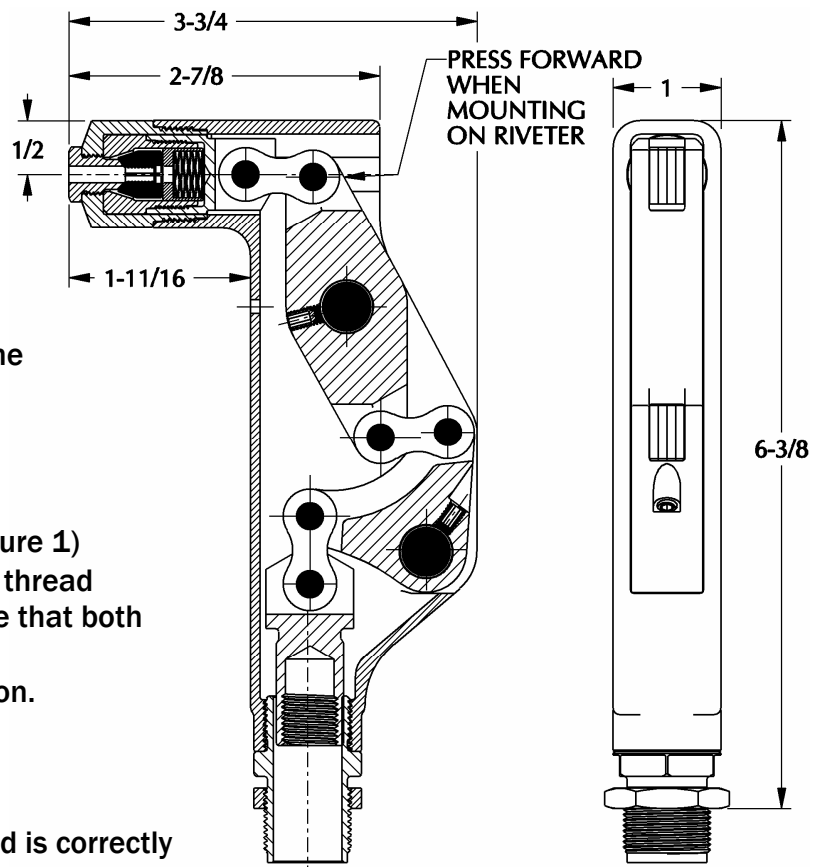

**CHERRY®**  
AEROSPACE

# H828-56MBP

## Right Angle Pulling Head for MaxiBolt® Plus fasteners

### TECHNICAL DATA SHEET, Page 2 of 2

#### PREVENTATIVE MAINTENANCE

- Inspect active area regularly and keep it clean, in good condition
- Clean the insert, jaws and jaw cavity inside the collet every 1,000 installations.
- Lubricate outside configuration of the jaws with Lubriplate® or similar light grease.
- Use Loctite® 242 (removable) on threaded components as shown.
- At assembly, thread in the set screws tightly (item 16), then back them off ¼ of a turn.

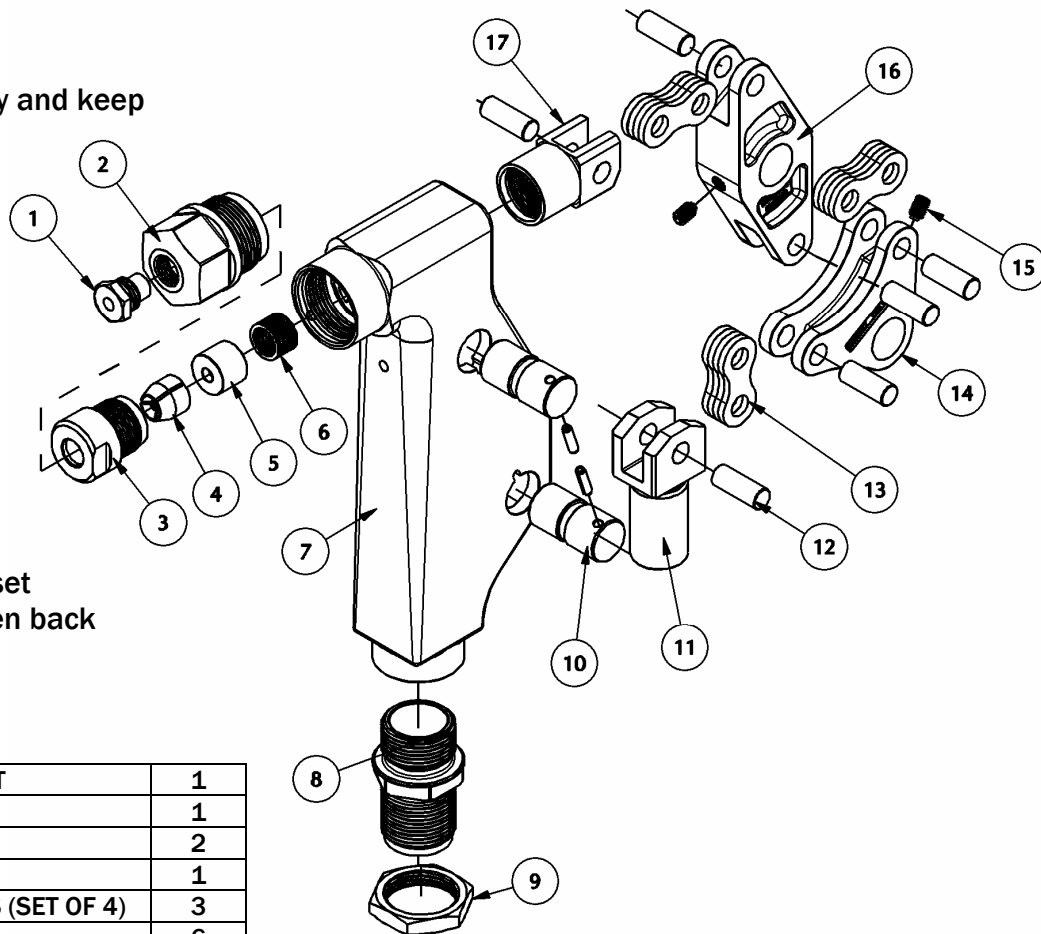

#### PARTS LIST

17	828B6	COLLET BOLT	1
16	828B3	LEVER	1
15	P-930	SET SCREW	2
14	828B4	BELL CRANK	1
13	828B15	LINK PLATES (SET OF 4)	3
12	828B14	LINK PIN	6
11	828B5	DRAWBOLT	1
10	828B13	PIVOT PIN ASSEMBLY	2
9	642A64	JAM NUT	1
8	828B7	ADAPTER FITTING	1
7	828C2-1	FRAME	1
6	P-1442	COMPRESSION SPRING	1
5	828-033	JAW FOLLOWER	1
4	652-043	JAWS (SET OF 3)	1
3	828C9	COLLET	1
2	828C8	SLEEVE	1
1	828-031	NOSEPIECE	1
<b>ITEM NO.</b>	<b>PART NUMBER</b>	<b>DESCRIPTION</b>	<b>QTY. PER ASSY.</b>

LOCTITE® is a registered trademark of Henkel Corporation.

LUBRIPLATE® is a registered trademark of Fiske Brothers Refining Co.

#### WARRANTY

Seller warrants the goods conform to applicable specifications and drawings and will be manufactured and inspected according to generally accepted practices of companies manufacturing industrial or aerospace fasteners. In the event of any breach of the foregoing warranty, Buyer's sole remedy shall be to return defective goods (after receiving authorization from Seller) for replacement or refund of the purchase price, at the Seller's option. Seller agrees to any freight costs in connection with the return of any defective goods, but any costs relating to removal of the defective or nonconforming goods or installation of replacement goods shall be Buyer's responsibility. SELLER'S WARRANTY DOES NOT APPLY WHEN ANY PHYSICAL OR CHEMICAL CHANGE IN THE FORM OF THE PRODUCT IS MADE BY BUYER. THE FOREGOING EXPRESS WARRANTY AND REMEDY ARE EXCLUSIVE AND ARE IN LIEU OF ALL OTHER WARRANTIES AND REMEDIES; ANY IMPLIED WARRANTY AS TO QUALITY, FITNESS FOR PURPOSE, OR MERCHANTABILITY IS HEREBY SPECIFICALLY DISCLAIMED AND EXCLUDED BY SELLER. This warranty is void if seller is not notified in writing of any rejection of the goods within ninety (90) days after receipt of the goods by buyer.

Seller shall not be liable under any circumstances for incidental, special or consequential damages arising in whole or in part from any breach by Seller, AND SUCH INCIDENTAL, SPECIAL, OR CONSEQUENTIAL DAMAGES ARE HEREBY EXPRESSLY EXCLUDED.

Our policy is one of continuous development. Specifications shown in this document may be subject to changes introduced after publication.

NOTE: The properties, strength, dimensions, installed characteristics and all other information in these materials are for guidance only to aid in the correct selection of the products described herein and is not intended or implied as part of the above warranty. All applications should be evaluated for functional stability and available samples of the described parts can be requested for installed tests, suitability and evaluations.

For more information please contact our Technical Services Department at tel. 714-850-6022



**CHERRY®**  
AEROSPACE