

# H827-8

## PULLING HEAD FOR CHERRYMAX® RIVETS

### INSTRUCTION SHEET

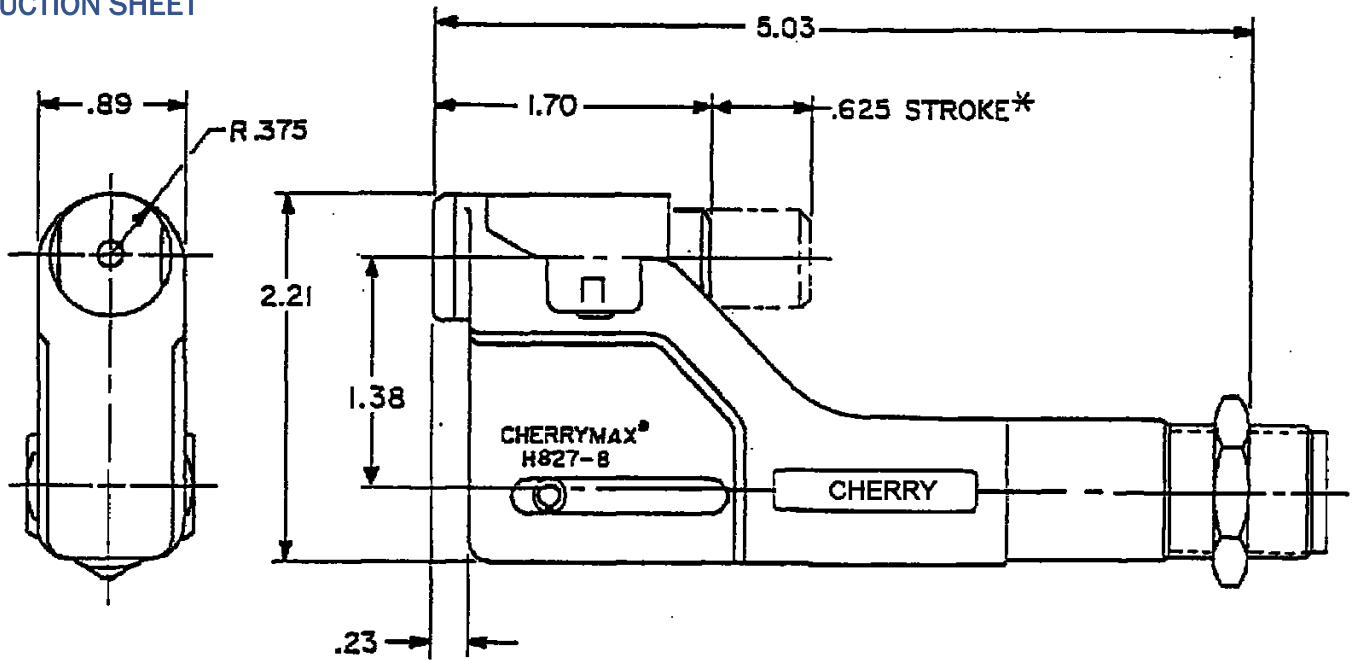

### CHOICE OF RIVETERS

- G744 Cherry® riveter (no adaptors necessary)
- G83 or G84 riveters with adapter 744-200

### USAGE

- The tool will install the nominal 8 diameter Cherrymax fasteners as provided
- To install the oversize version, add 563A46 (item 11) to the Snubber Assembly

### ASSEMBLY AND MAINTENANCE (SEE PARTS LIST)

- Lubricate the sliding areas between drawbolt (6) and frame (8) regularly with light oil.
- Keep the pulling head clean and in good working condition.

### TO DISASSEMBLE

- Unthread the drawbolt extension (7) with a 3/8" hex key.
- Remove the guard (2).
- Remove the roll-pin (10) with a drift pin.
- Lift the drawbolt (3) out of the frame (9).
- To remove jaws (4) use 1" wrench to remove the snubber assy. (6).

**NOTE:** Replace any worn out components and re-assemble;  
Use Loctite® 242 on the threaded components



**CHERRY®**  
AEROSPACE

1224 East Warner Ave,  
Santa Ana, Ca 92705  
Tel: 1-714-545-5511  
www.cherryaerospace.com

# H827-8

## PULLING HEAD FOR CHERRYMAX® RIVETS

### INSTRUCTION SHEET

### PARTS LIST

Item No.	Qty.	Part No.	Description
1	1	827-015	Nosepiece
2	1	827-014	GUARD
3	1	827-012	DRAWBOLT
4	1	563C35	J AWS (SET OF 3)
5	1	P-1267	O-RING
6	1	827-004	SNUBBER ASSY
7	1	827-013	DRAWBOLT EXTENSION
8	1	642A64	JAM NUT
9	1	827-011	FRAME
10	1	P-1248	ROLL PIN
11	1	563A46	WASHER (SEE NOTE)

Note: ADD ITEM 11 ONLY WHEN INSTALLING OVERSIZE CHERRYMAX FASTENERS

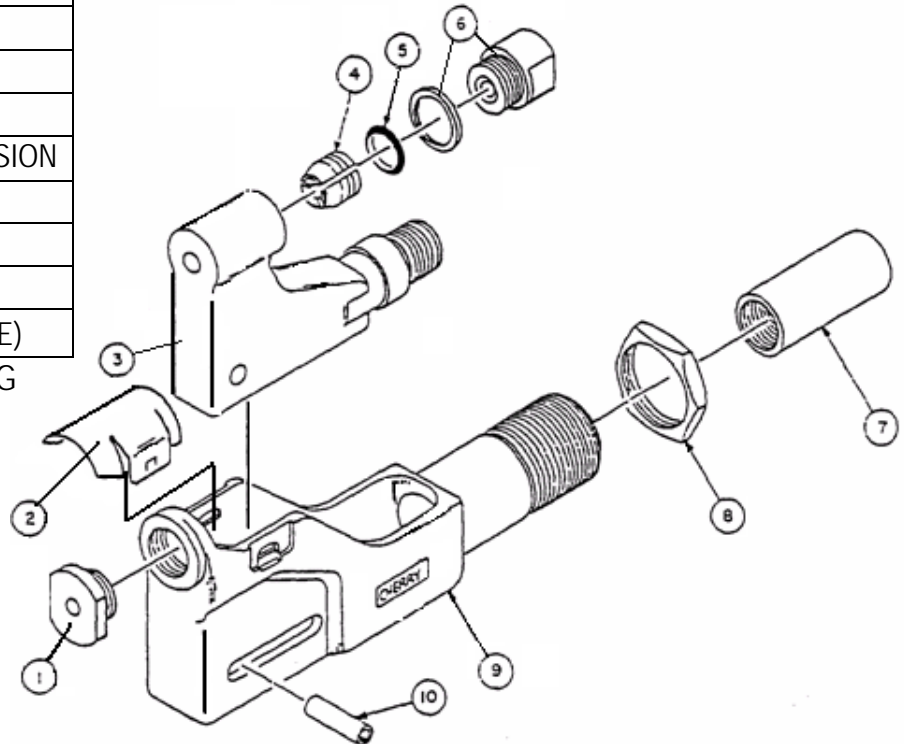

### WARRANTY

Seller warrants the goods conform to applicable specifications and drawings and will be manufactured and inspected according to generally accepted practices of companies manufacturing industrial or aerospace fasteners. In the event of any breach of the foregoing warranty, Buyer's sole remedy shall be to return defective goods (after receiving authorization from Seller) for replacement or refund of the purchase price, at the Seller's option. Seller agrees to any freight costs in connection with the return of any defective goods, but any costs relating to removal of the defective or nonconforming goods or installation of replacement goods shall be Buyer's responsibility. SELLER'S WARRANTY DOES NOT APPLY WHEN ANY PHYSICAL OR CHEMICAL CHANGE IN THE FORM OF THE PRODUCT IS MADE BY BUYER. THE FOREGOING EXPRESS WARRANTY AND REMEDY ARE EXCLUSIVE AND ARE IN LIEU OF ALL OTHER WARRANTIES AND REMEDIES; ANY IMPLIED WARRANTY AS TO QUALITY, FITNESS FOR PURPOSE, OR MERCHANTABILITY IS HEREBY SPECIFICALLY DISCLAIMED AND EXCLUDED BY SELLER. This warranty is void if seller is not notified in writing of any rejection of the goods within ninety (90) days after receipt of the goods by buyer.

Seller shall not be liable under any circumstances for incidental, special or consequential damages arising in whole or in part from any breach by Seller, AND SUCH INCIDENTAL, SPECIAL, OR CONSEQUENTIAL DAMAGES ARE HEREBY EXPRESSLY EXCLUDED.

Our policy is one of continuous development. Specifications shown in this document may be subject to changes introduced after publication.

NOTE: The properties, strength, dimensions, installed characteristics and all other information in these materials are for guidance only to aid in the correct selection of the products described herein and is not intended or implied as part of the above warranty. All applications should be evaluated for functional stability and available samples of the described parts can be requested for installed tests, suitability and evaluations.

For more information please contact our Technical Services Department at tel. 714-850-6022



**CHERRY**®  
AEROSPACE

1224 East Warner Ave,  
Santa Ana, Ca 92705  
Tel: 1-714-545-5511  
www.cherryaerospace.com