

H721-4-60 RIVETLESS NUT PLATE PULLING HEAD INSTRUCTION SHEET

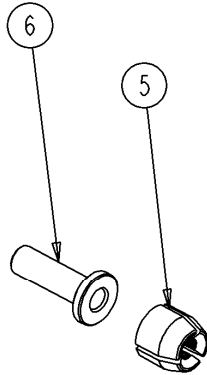

9	1	671A16	Nut, 3/4 -20 UNEF
8	1	747-042	Drawbar
7	1	P-1423	Spring, compression
6	1	747-054	Follower, jaw, H721-4
5	1	563-031	Jaws, set of 3
4	1	747-048	Collet, H721
3	1	747-053	Sleeve, H721-4
2	1	747-052	Nosepiece, H721-4-60
1	1	747-051	Insert, H721-4-60
ITEM NUMBER	QTY. PER ASSY.	PART NUMBER	DESCRIPTION

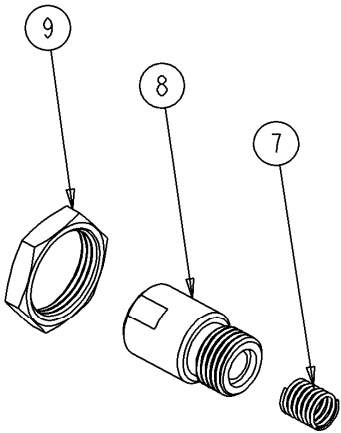
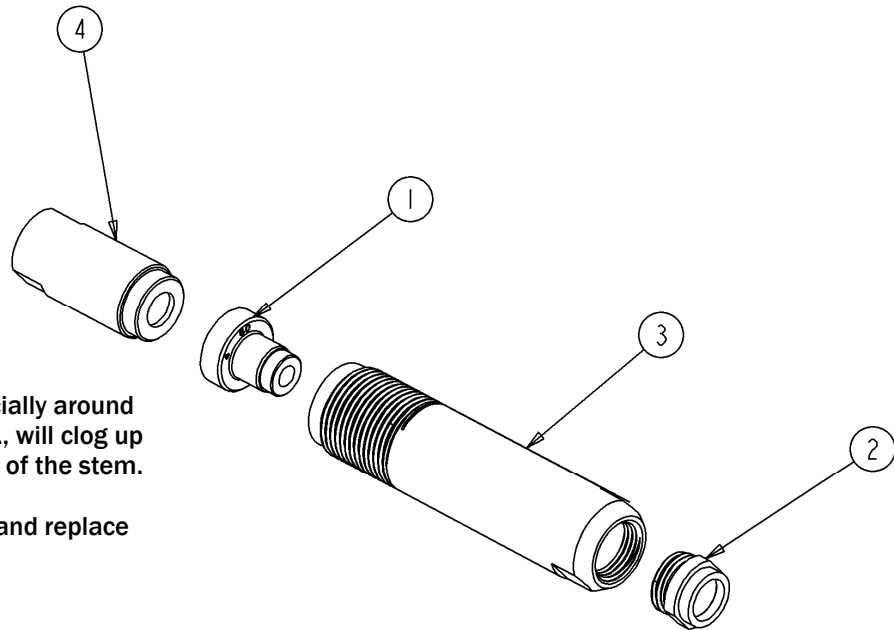

INSTRUCTIONS

1. Make certain the pulling head is kept clean, especially around the riveting end, as adhesives, chips, sealants, etc., will clog up the serrations of the jaws and may cause slippage of the stem.
2. In case of damage to the pulling head, dismantle and replace with parts selected from the list above.

PREVENTATIVE MAINTENANCE

1. Lubricate the jaws and collet every 1,000 installations.

WARRANTY

Seller warrants the goods conform to applicable specifications and drawings and will be manufactured and inspected according to generally accepted practices of companies manufacturing industrial or aerospace fasteners. In the event of any breach of the foregoing warranty, Buyer's sole remedy shall be to return defective goods (after receiving authorization from Seller) for replacement or refund of the purchase price, at the Seller's option. Seller agrees to any freight costs in connection with the return of any defective goods, but any costs relating to removal of the defective or nonconforming goods or installation of replacement goods shall be Buyer's responsibility. SELLER'S WARRANTY DOES NOT APPLY WHEN ANY PHYSICAL OR CHEMICAL CHANGE IN THE FORM OF THE PRODUCT IS MADE BY BUYER. THE FOREGOING EXPRESS WARRANTY AND REMEDY ARE EXCLUSIVE AND ARE IN LIEU OF ALL OTHER WARRANTIES AND REMEDIES; ANY IMPLIED WARRANTY AS TO QUALITY, FITNESS FOR PURPOSE, OR MERCHANTABILITY IS HEREBY SPECIFICALLY DISCLAIMED AND EXCLUDED BY SELLER. This warranty is void if seller is not notified in writing of any rejection of the goods within ninety (90) days after receipt of the goods by buyer.

Seller shall not be liable under any circumstances for incidental, special or consequential damages arising in whole or in part from any breach by Seller, AND SUCH INCIDENTAL, SPECIAL, OR CONSEQUENTIAL DAMAGES ARE HEREBY EXPRESSLY EXCLUDED.

Our policy is one of continuous development. Specifications shown in this document may be subject to changes introduced after publication.

NOTE: The properties, strength, dimensions, installed characteristics and all other information in these materials are for guidance only to aid in the correct selection of the products described herein and is not intended or implied as part of the above warranty. All applications should be evaluated for functional stability and available samples of the described parts can be requested for installed tests, suitability and evaluations.

For more information please contact our Technical Services Department at tel. 714-850-6022



CHERRY[®]
AEROSPACE