

H721-3-60

RIVETLESS NUT PLATE PULLING HEAD

INSTRUCTION SHEET, Page 1 of 2

DIMENSIONAL DATA (see figure 1; all measurements in Inches)

- Tool Weight (without riveter): 0.25 Lbs (0.113 Kg)

CHOICE OF RIVETERS

- The Pulling Head is recommended to be used with **G704B Cherry Riveters**.

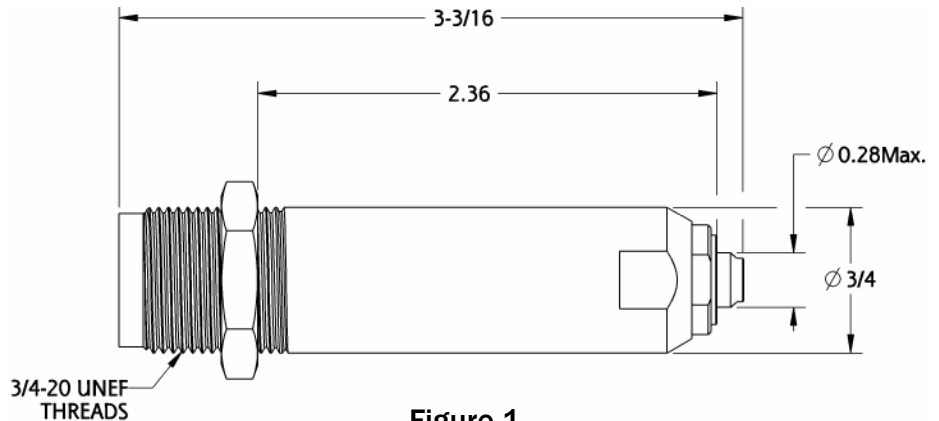

MOUNTING INSTRUCTIONS

- Attach Riveter to air source for correct piston positioning.
- Thread the Pulling Head onto the Riveter; make sure that both internal and external components are properly threaded in and tightened.
- Lock Sleeve in position by tightening the Jam Nut.

Caution: Do not use thread locker (Example: Loctite®) on the Drawbar and Jam Nut internal threads.

BEFORE USE

- The Pulling Head is correctly mounted and the proper riveter is selected.
- Proper air source is connected (see Riveter specification for recommended pressure).
- Make sure that the tool is clean and in good working condition.

USAGE

- This tool was designed to install Rivetless Nut Plate fasteners having a #10-32 or M5 Nut with 0.060" float (Ex: CNP11C3).

DURING OPERATION

- Inspect the active area of the Nosepiece regularly.
- Keep the tool clean, especially the Nosepiece and Jaws; pay special attention when used with sealants and adhesives.
- If stem slippage occurs, the Jaws need to be either cleaned or replaced.



CHERRY®
AEROSPACE

H721-3-60

RIVETLESS NUT PLATE PULLING HEAD

INSTRUCTION SHEET, Page 2 of 2

PREVENTATIVE MAINTENANCE

- Clean the Insert, Jaws and Jaw Cavity inside the Collet every 1,000 installations.
- Lubricate outside configuration of the Jaws with Lubriplate® or similar light grease.
- Inspect regularly and keep active area clean and in good working condition.
- Replace worn or broken components.
- When re-assembling use Loctite® 242 (removable) on threaded components as shown

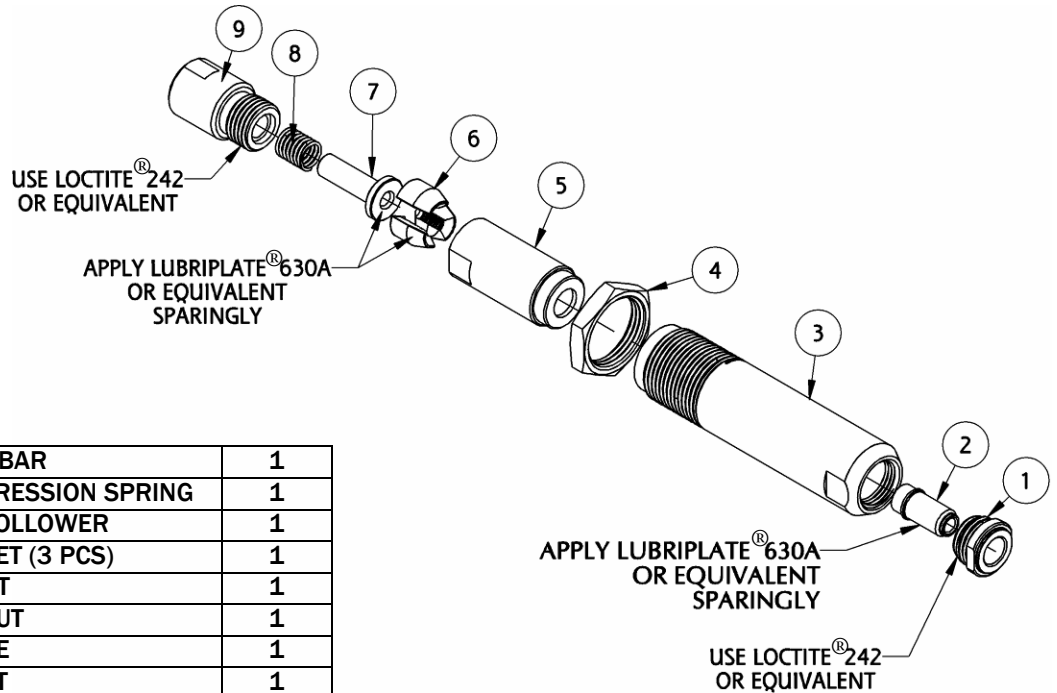

PARTS LIST

9	747-042	DRAWBAR	1
8	P-1423	COMPRESSION SPRING	1
7	747-049	JAW FOLLOWER	1
6	652-043	JAW SET (3 PCS)	1
5	747-048	COLLET	1
4	671A16	JAM NUT	1
3	747-053	SLEEVE	1
2	747-086	INSERT	1
1	747-085	NOSEPIECE	1
ITEM NUMBER	PART NUMBER	DESCRIPTION	QTY. PER ASSY.

LOCTITE® is a registered trademark of Henkel Corporation.
LUBRIPLATE® is a registered trademark of Fiske Brothers Refining Co.

WARRANTY

Seller warrants the goods conform to applicable specifications and drawings and will be manufactured and inspected according to generally accepted practices of companies manufacturing industrial or aerospace fasteners. In the event of any breach of the foregoing warranty, Buyer's sole remedy shall be to return defective goods (after receiving authorization from Seller) for replacement or refund of the purchase price, at the Seller's option. Seller agrees to any freight costs in connection with the return of any defective goods, but any costs relating to removal of the defective or nonconforming goods or installation of replacement goods shall be Buyer's responsibility. SELLER'S WARRANTY DOES NOT APPLY WHEN ANY PHYSICAL OR CHEMICAL CHANGE IN THE FORM OF THE PRODUCT IS MADE BY BUYER. THE FOREGOING EXPRESS WARRANTY AND REMEDY ARE EXCLUSIVE AND ARE IN LIEU OF ALL OTHER WARRANTIES AND REMEDIES; ANY IMPLIED WARRANTY AS TO QUALITY, FITNESS FOR PURPOSE, OR MERCHANTABILITY IS HEREBY SPECIFICALLY DISCLAIMED AND EXCLUDED BY SELLER. This warranty is void if seller is not notified in writing of any rejection of the goods within ninety (90) days after receipt of the goods by buyer.

Seller shall not be liable under any circumstances for incidental, special or consequential damages arising in whole or in part from any breach by Seller, AND SUCH INCIDENTAL, SPECIAL, OR CONSEQUENTIAL DAMAGES ARE HEREBY EXPRESSLY EXCLUDED.

Our policy is one of continuous development. Specifications shown in this document may be subject to changes introduced after publication.

NOTE: The properties, strength, dimensions, installed characteristics and all other information in these materials are for guidance only to aid in the correct selection of the products described herein and is not intended or implied as part of the above warranty. All applications should be evaluated for functional stability and available samples of the described parts can be requested for installed tests, suitability and evaluations.

For more information please contact our Technical Services Department at tel. 714-850-6022



CHERRY®
AEROSPACE