

H704-()NP RIVETLESS NUT PLATE® PULLING HEAD

Technical Data Sheet, Page 1 of 2

DIMENSIONAL DATA

(see figure, all measurements in Inches)

- Tool weight (without riveter): .25 Lbs (0.113 Kg).

CHOICE OF RIVETERS

- **G704B** Cherry® Riveter
- **G750A** Cherry® Hand Riveter with adaptor 750A-088

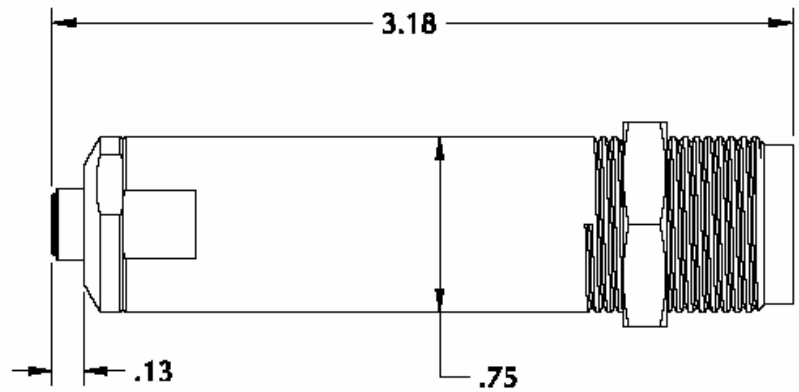

MOUNTING INSTRUCTIONS

- Attach riveter to air source for correct piston positioning; for hand powered riveters (G750A), make sure that the pressure has been released and that the correct adaptors are used.
- Thread collet assembly securely onto the riveter head piston, then the sleeve assembly into the riveter housing. Use jam nut (item 6) to secure sleeve assembly in desired position for optimal installation and stem front ejection.

USAGE

- The H704-()NP family of tools is designed to reliably install both short stem and standard Cherry® Rivetless NutPlates
- It is a modular system, capable of installing any size under 5/16" with the correct nose piece; for the correct selection, see Table 1. Select based on the size of the hole where the RNP will be installed into. Consult the Standards Page for hole preparation and other fastener related information.

BEFORE USE, MAKE SURE THAT:

- The nose piece and insert are properly mounted on the recommended riveter
- Proper air source is connected.

DURING OPERATION

- Inspect the active area of the nose piece regularly.
- Keep the tool clean, especially the nose piece and jaws; pay special attention when sealants are used.
- If stem slippage occurs, the jaws need to be either cleaned or replaced.

PREVENTATIVE MAINTENANCE

- Clean the nose piece, jaw set and collet every 1,000 installations, or when failures occurs; use a wire brush to clean the copper deposited inside the jaw set.
- Lubricate outside of the jaw set with Lubriplate® or similar light lubricant.



CHERRY®
AEROSPACE

H704-()NP RIVETLESS NUT PLATE® PULLING HEAD

Technical Data Sheet, Page 2 of 2

PARTS LIST

9	See Table 1	NOSE PIECE	1
8	See Table 1	INSERT	1
7	652-114	SLEEVE	1
6	671A16	JAM NUT	1
5	652-115	COLLET	1
4	652-043	JAW SET	1
3	652-116	JAW FOLLOWER	1
2	P1442	COMPRESSION SPRING	1
1	747-042	DRAWBAR	1
ITEM No.	PART NUMBER	DESCRIPTION	QTY. PER

- When re-assembling use Loctite® 242 (removable) on the Nose Piece and Collet threads.

Table 1. Nose Piece & Insert Selection

PULLING HEAD	INSTALLATION HOLE DIA.	NOSE PIECE	INSERT
H704-223NP	.223" Min	652-162	652-163
H704-249NP	.249" Min	652-117	652-120
H704-280NP	.280" Min	652-118	652-121
H704-295NP	.295" Min	652-132	652-133
H704-311NP	.311" Min	652-119	652-122
H704-343NP	.343" Min	652-126	652-127
H704-358NP	.358" Min	652-135	652-136

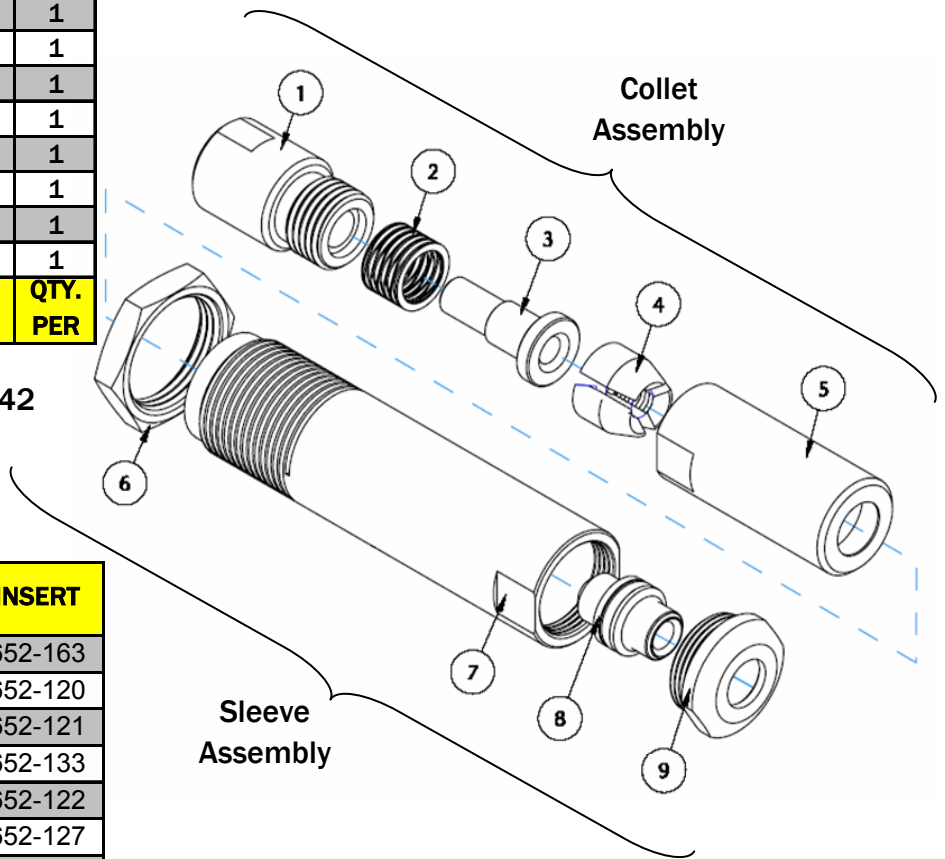

GENERAL / TECHNICAL QUESTIONS

1224 E. Warner Avenue
Santa Ana, CA 92705 USA
1-714-850-6022 (Phone)
1-714-850-6093 (Fax)

LOCTITE® is a registered trademark of Henkel Corporation.
LUBRIPLATE® is a registered trademark of Fiske Brothers Refining Co.

WARRANTY

Seller warrants the goods conform to applicable specifications and drawings and will be manufactured and inspected according to generally accepted practices of companies manufacturing industrial or aerospace fasteners. In the event of any breach of the foregoing warranty, Buyer's sole remedy shall be to return defective goods (after receiving authorization from Seller) for replacement or refund of the purchase price, at the Seller's option. Seller agrees to any freight costs in connection with the return of any defective goods, but any costs relating to removal of the defective or nonconforming goods or installation of replacement goods shall be Buyer's responsibility. SELLER'S WARRANTY DOES NOT APPLY WHEN ANY PHYSICAL OR CHEMICAL CHANGE IN THE FORM OF THE PRODUCT IS MADE BY BUYER. THE FOREGOING EXPRESS WARRANTY AND REMEDY ARE EXCLUSIVE AND ARE IN LIEU OF ALL OTHER WARRANTIES AND REMEDIES; ANY IMPLIED WARRANTY AS TO QUALITY, FITNESS FOR PURPOSE, OR MERCHANTABILITY IS HEREBY SPECIFICALLY DISCLAIMED AND EXCLUDED BY SELLER. This warranty is void if seller is not notified in writing of any rejection of the goods within ninety (90) days after receipt of the goods by buyer.

Seller shall not be liable under any circumstances for incidental, special or consequential damages arising in whole or in part from any breach by Seller, AND SUCH INCIDENTAL, SPECIAL, OR CONSEQUENTIAL DAMAGES ARE HEREBY EXPRESSLY EXCLUDED.

Our policy is one of continuous development. Specifications shown in this document may be subject to changes introduced after publication.

NOTE: The properties, strength, dimensions, installed characteristics and all other information in these materials are for guidance only to aid in the correct selection of the products described herein and is not intended or implied as part of the above warranty. All applications should be evaluated for functional stability and available samples of the described parts can be requested for installed tests, suitability and evaluations.

For more information please contact our Technical Services Department at tel. 714-850-6022



CHERRY®
AEROSPACE

1224 East Warner Ave,
Santa Ana, Ca 92705
Tel: 1-714-545-5511
www.cherryaerospace.com