

H701B-456

Straight Pulling Head for CHERRYMAX[®] fasteners

INSTRUCTION SHEET, Page 1 of 2

Fig. 1. Dimensional Data

DIMENSIONAL DATA (see Fig. 1)

- Weight: 0.15 Lbs.

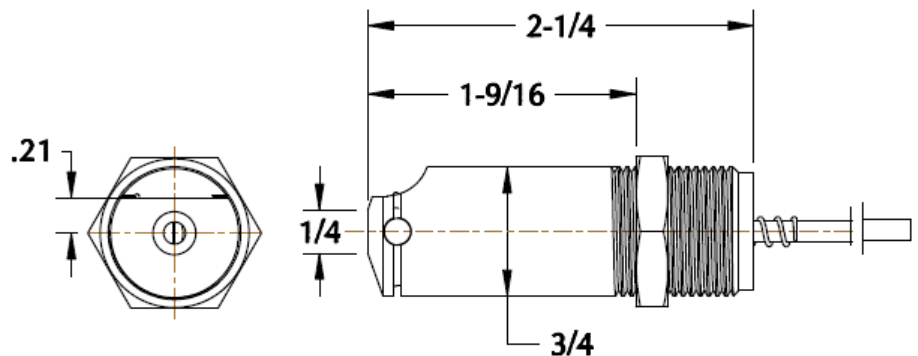

CHOICE OF RIVETERS

- G746A (1850 Lbs @ 90 PSI, 7/8" stroke)
- G747 (2100 Lbs @ 90 PSI, 7/16 stroke)
- G704B (3100 Lbs @ 90 PSI, 1/2" stroke)
- G800 (4200 Lbs, 3/4" stroke, hand powered)

MOUNTING INSTRUCTIONS

- Attach Riveter to air source; place the spring into the riveter piston
- Carefully thread in and tighten the collet assembly onto the riveter piston
- Thread in the sleeve assy and lock it in by tightening the Jam Nut.

JAW ADJUSTMENT

The jaws can be adjusted to hold onto the stem in position at all times or to fully release it before and after fastener installation

- Push the fastener all the way through the nosepiece.
- *To grab onto the stem:* Unthread the sleeve while moving the fastener in and out until you feel the desired jaw hold.
- *To release the stem:* Thread the sleeve in until the stem is released
- After adjustment, lock in position by tightening the Jam Nut.

OPERATING INSTRUCTIONS

Before operating the tool, make sure that:

- Pulling Head is correctly mounted on the proper riveter
- Proper Air source is connected (see Riveter manual for air pressure).
- The Jaw follower must be replaced by the extended one (955-011) when installing 4 diameter fasteners to prevent stem shingling.

During Operation:

- Inspect the active area of the nosepiece regularly.
- Keep the tool clean, especially the nosepiece and jaws; pay special attention when sealants and adhesives are used.
- If stem slippage occurs, clean or replace the jaws.



CHERRY[®]
AEROSPACE

1224 East Warner Ave,
Santa Ana, CA 92705
Tel: 1-714-545-5511
www.cherryaerospace.com

H701B-456

Straight Pulling Head for CHERRYMAX® fasteners

INSTRUCTION SHEET, Page 2 of 2

PARTS LIST

ITEM No	PART NUMBER	DESCRIPTION	QTY.
1	701B21	SLEEVE	1
2	701B25	RETAINING SPRING	1
3	701B24	STEM STOP (FINGER)	1
4	671A16	JAM NUT	1
5	701B29A	COLLET	1
6	701B18	JAW SET (2 PCS)	1
7a	753A14A	JAW FOLLOWER	1
7b	955-011	EXTENDED JAW FOLLOWER	1
8	701A33	BUMPER	1
9	P-1155	COMPRESSION SPRING	1

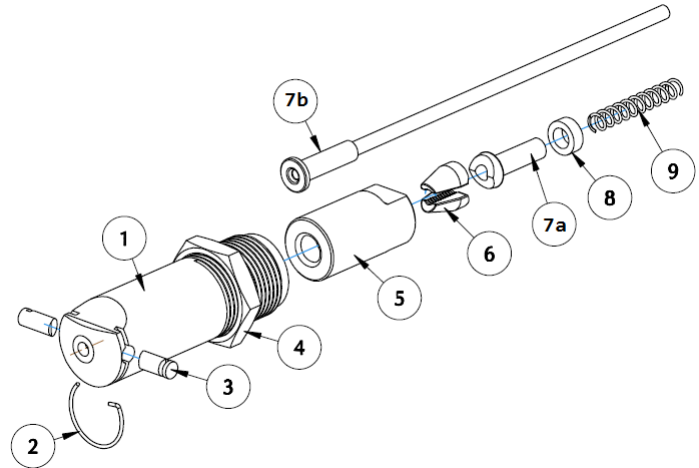

Replace item 7a (753A14A- JAW FOLLOWER) with item 7b (955-011- EXTENDED JAW FOLLOWER) when installing 4 diameter fasteners to prevent stems from shingling inside the pulling head.

PREVENTATIVE MAINTENANCE

- Clean and inspect the nosepiece, jaws, collet & spring every 1000 installations or whenever a failure occurs; replace spring and jaws if worn.
- Lubricate outside configuration of the jaws with Lubriplate® or similar light grease.
- Inspect regularly and keep active area clean and in good working condition.
- Replace worn or broken components.
- When re-assembling align the jaws with the jaw follower as shown in the exploded view (items 6 and 7a).

LOCTITE® is a registered trademark of Henkel Corporation.

LUBRIPLATE® is a registered trademark of Fiske Brothers Refining Co.

WARRANTY

Seller warrants the goods conform to applicable specifications and drawings and will be manufactured and inspected according to generally accepted practices of companies manufacturing industrial or aerospace fasteners. In the event of any breach of the foregoing warranty, Buyer's sole remedy shall be to return defective goods (after receiving authorization from Seller) for replacement or refund of the purchase price, at the Seller's option. Seller agrees to any freight costs in connection with the return of any defective goods, but any costs relating to removal of the defective or nonconforming goods or installation of replacement goods shall be Buyer's responsibility. SELLER'S WARRANTY DOES NOT APPLY WHEN ANY PHYSICAL OR CHEMICAL CHANGE IN THE FORM OF THE PRODUCT IS MADE BY BUYER. THE FOREGOING EXPRESS WARRANTY AND REMEDY ARE EXCLUSIVE AND ARE IN LIEU OF ALL OTHER WARRANTIES AND REMEDIES; ANY IMPLIED WARRANTY AS TO QUALITY, FITNESS FOR PURPOSE, OR MERCHANTABILITY IS HEREBY SPECIFICALLY DISCLAIMED AND EXCLUDED BY SELLER. This warranty is void if seller is not notified in writing of any rejection of the goods within ninety (90) days after receipt of the goods by buyer.

Seller shall not be liable under any circumstances for incidental, special or consequential damages arising in whole or in part from any breach by Seller, AND SUCH INCIDENTAL, SPECIAL, OR CONSEQUENTIAL DAMAGES ARE HEREBY EXPRESSLY EXCLUDED.

Our policy is one of continuous development. Specifications shown in this document may be subject to changes introduced after publication.

NOTE: The properties, strength, dimensions, installed characteristics and all other information in these materials are for guidance only to aid in the correct selection of the products described herein and is not intended or implied as part of the above warranty. All applications should be evaluated for functional stability and available samples of the described parts can be requested for installed tests, suitability and evaluations.



CHERRY®
AEROSPACE

1224 East Warner Ave,
Santa Ana, CA 92705
Tel: 1-714-545-5511
www.cherryaerospace.com