

# 839C1 & 839C10

## Hollow End E-Z Buck Flaring Dies

INSTRUCTION SHEET, Page 1 of 1

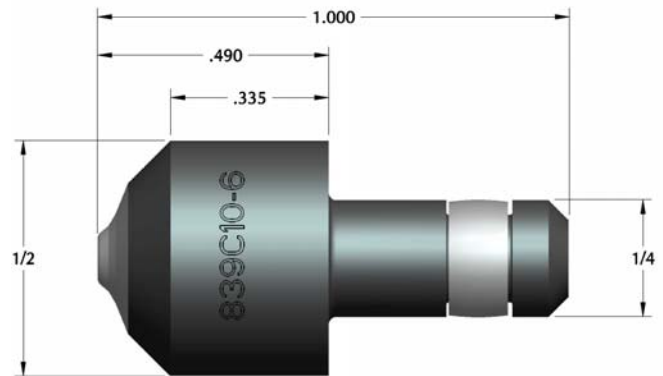
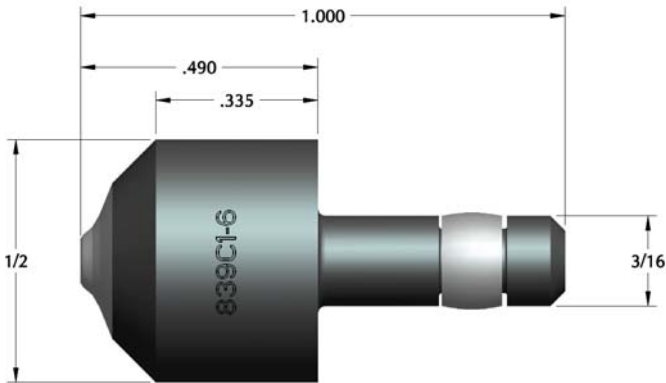

### 839C1 (3/16" mount)

- 839C1-4 (4 diameter rivets)
- 839C1-5 (5 diameter rivets)
- 839C1-6 (6 diameter rivets)
- 839C1-7 (7 diameter rivets)

### 839C10 (1/4" mount)

- 839C10-4 (4 diameter rivets)
- 839C10-5 (5 diameter rivets)
- 839C10-6 (6 diameter rivets)
- 839C10-7 (7 diameter rivets)

### CHOICE OF RIVETERS

This die will work with either automatic riveting machines or a pneumatic squeezer; use 839B3 (3/16 mount) and 839B13 (1/4" mount)

### OPERATING INSTRUCTIONS

Before operating the tool, make sure that:

- The die is clean and in good working condition; if the flaring portion of the die is damaged, replace.
- Proper Air source is connected (see Squeezer manual for air pressure).

### PREVENTATIVE MAINTENANCE

- Inspect the flaring area of the die for signs of wear and galling; re-polish if it is dirty or galled up.

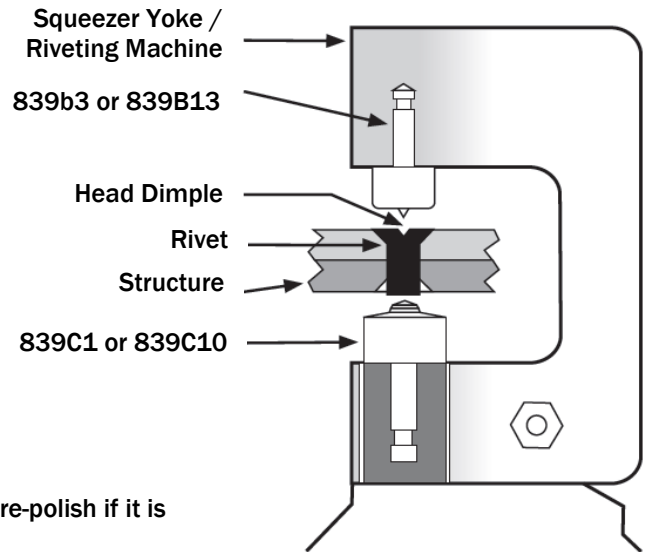

### WARRANTY

Seller warrants the goods conform to applicable specifications and drawings and will be manufactured and inspected according to generally accepted practices of companies manufacturing industrial or aerospace fasteners. In the event of any breach of the foregoing warranty, Buyer's sole remedy shall be to return defective goods (after receiving authorization from Seller) for replacement or refund of the purchase price, at the Seller's option. Seller agrees to any freight costs in connection with the return of any defective goods, but any costs relating to removal of the defective or nonconforming goods or installation of replacement goods shall be Buyer's responsibility. SELLER'S WARRANTY DOES NOT APPLY WHEN ANY PHYSICAL OR CHEMICAL CHANGE IN THE FORM OF THE PRODUCT IS MADE BY BUYER. THE FOREGOING EXPRESS WARRANTY AND REMEDY ARE EXCLUSIVE AND ARE IN LIEU OF ALL OTHER WARRANTIES AND REMEDIES; ANY IMPLIED WARRANTY AS TO QUALITY, FITNESS FOR PURPOSE, OR MERCHANTABILITY IS HEREBY SPECIFICALLY DISCLAIMED AND EXCLUDED BY SELLER. This warranty is void if seller is not notified in writing of any rejection of the goods within ninety (90) days after receipt of the goods by buyer.

Seller shall not be liable under any circumstances for incidental, special or consequential damages arising in whole or in part from any breach by Seller, AND SUCH INCIDENTAL, SPECIAL, OR CONSEQUENTIAL DAMAGES ARE HEREBY EXPRESSLY EXCLUDED.

Our policy is one of continuous development. Specifications shown in this document may be subject to changes introduced after publication.

NOTE: The properties, strength, dimensions, installed characteristics and all other information in these materials are for guidance only to aid in the correct selection of the products described herein and is not intended or implied as part of the above warranty. All applications should be evaluated for functional stability and available samples of the described parts can be requested for installed tests, suitability and evaluations.



**CHERRY**<sup>®</sup>  
AEROSPACE

1224 East Warner Ave,  
Santa Ana, CA 92705  
Tel: 1-714-545-5511

[www.cherryaerospace.com](http://www.cherryaerospace.com)