

744-800
 ADAPTOR KIT FROM G84-LS to H84B-568
INSTRUCTION SHEET, Page 1 of 1

- Use this adaptor kit to adapt the G84-LS riveter to mount the H84B-568 Maxibolt Plus pulling head.

Components included:

ITEM No	PART NUMBER	DESCRIPTION	QTY.
1	744-801	SLEEVE ADAPTOR	1
2	744-802	DRAWBOLT ADAPTOR	1

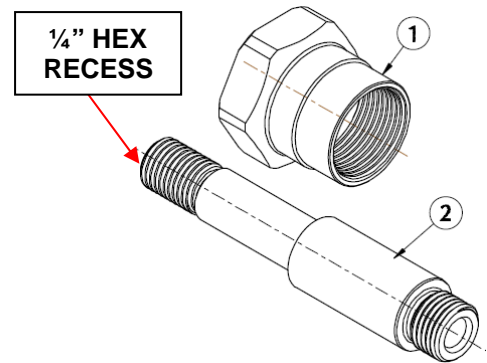

Mounting Instructions:

- **Pulling Head preparation** (see TS-H84B-568 for details on the pulling head):
 - Remove 652-050 (Sleeve Adaptor)
 - Remove 652-049 (Drawbar Adaptor) and replace with 744-802 (item 2)
- **Mounting on the Riveter** (see TM-G84-LS for riveter breakdown) :
 - Remove P85 and 744-145 (socket head screw and PH Stop)
 - Thread the Sleeve Adaptor (item 1) onto the riveter until tightened, then orient it so one of the driving flats is oriented with the threaded hole from which P85 was removed from;
 - Thread P85 and 744-145 back in to lock the adaptor in place;
 - Thread the Drawbolt Adaptor (item 2) assembly into the riveter piston; use the 1/4" hex socket at the back end of the adaptor to drive it in and tighten it securely.

CAUTION:

- When used with pull through pulling heads, high velocity stems will be ejected at the back of the riveter. It is recommended to use the adaptor and stem deflector shown below to prevent injuries.
- These components are not included in this kit; they work with any of the Cherry™ adaptor kits available for this riveter

ITEM No	PART NUMBER	DESCRIPTION	QTY.
1	744-503	ADAPTOR	1
2	530A16	PIN DEFLECTOR	1

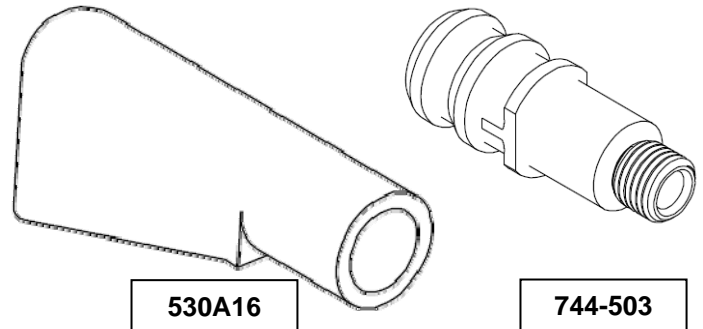

OTHER ADAPTOR KITS AVAILABLE FOR G84-LS

PART NUMBER	ADAPTS
744-500	G84-LS TO G744
744-600	G84-LS TO G704B
744-700	G84-LS TO G84 (BAYONET)
744-800	G84-LS TO H84B-568

WARRANTY

Seller warrants the goods conform to applicable specifications and drawings and will be manufactured and inspected according to generally accepted practices of companies manufacturing industrial or aerospace fasteners. In the event of any breach of the foregoing warranty, Buyer's sole remedy shall be to return defective goods (after receiving authorization from Seller) for replacement or refund of the purchase price, at the Seller's option. Seller agrees to any freight costs in connection with the return of any defective goods, but any costs relating to removal of the defective or nonconforming goods or installation of replacement goods shall be Buyer's responsibility. SELLER'S WARRANTY DOES NOT APPLY WHEN ANY PHYSICAL OR CHEMICAL CHANGE IN THE FORM OF THE PRODUCT IS MADE BY BUYER. THE FOREGOING EXPRESS WARRANTY AND REMEDY ARE EXCLUSIVE AND ARE IN LIEU OF ALL OTHER WARRANTIES AND REMEDIES; ANY IMPLIED WARRANTY AS TO QUALITY, FITNESS FOR PURPOSE, OR MERCHANTABILITY IS HEREBY SPECIFICALLY DISCLAIMED AND EXCLUDED BY SELLER. This warranty is void if seller is not notified in writing of any rejection of the goods within ninety (90) days after receipt of the goods by buyer.

Seller shall not be liable under any circumstances for incidental, special or consequential damages arising in whole or in part from any breach by Seller, AND SUCH INCIDENTAL, SPECIAL, OR CONSEQUENTIAL DAMAGES ARE HEREBY EXPRESSLY EXCLUDED.

Our policy is one of continuous development. Specifications shown in this document may be subject to changes introduced after publication.

NOTE: The properties, strength, dimensions, installed characteristics and all other information in these materials are for guidance only to aid in the correct selection of the products described herein and is not intended or implied as part of the above warranty. All applications should be evaluated for functional stability and available samples of the described parts can be requested for installed tests, suitability and evaluations.



CHERRY®
AEROSPACE

1224 East Warner Ave,
 Santa Ana, CA 92705
 Tel: 1-714-545-5511

www.cherryaerospace.com