

704A12

CHERRYMAX® EXTENSIONS

INSTRUCTION SHEET

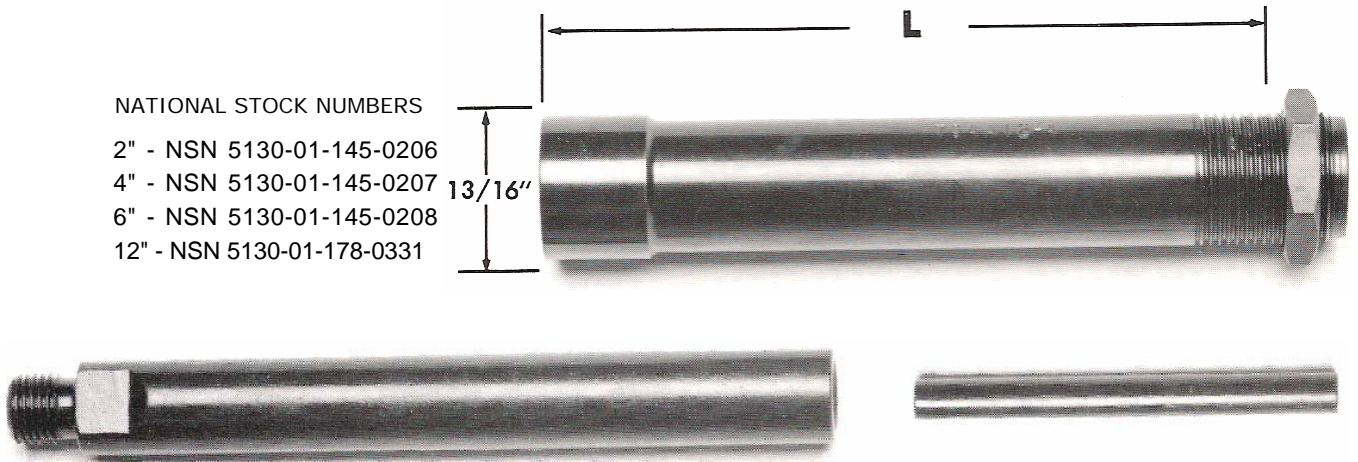

These extensions help reach many restricted installation areas by increasing the overall length of the pulling head. They fit directly on the G701, G747, G704, G746, G749, or G845 CherryMAX® riveters and will accept any of the CherryMAX® pulling heads.

There are four extension lengths (L) offered:

- 704A12-2 for 2" extension,
- 704A12-4 for 4" extension,
- 704A12-6 for 6" extension
- 704A12-12 for 12" extension

INSTALLING 704A12 EXTENSION ON RIVETER

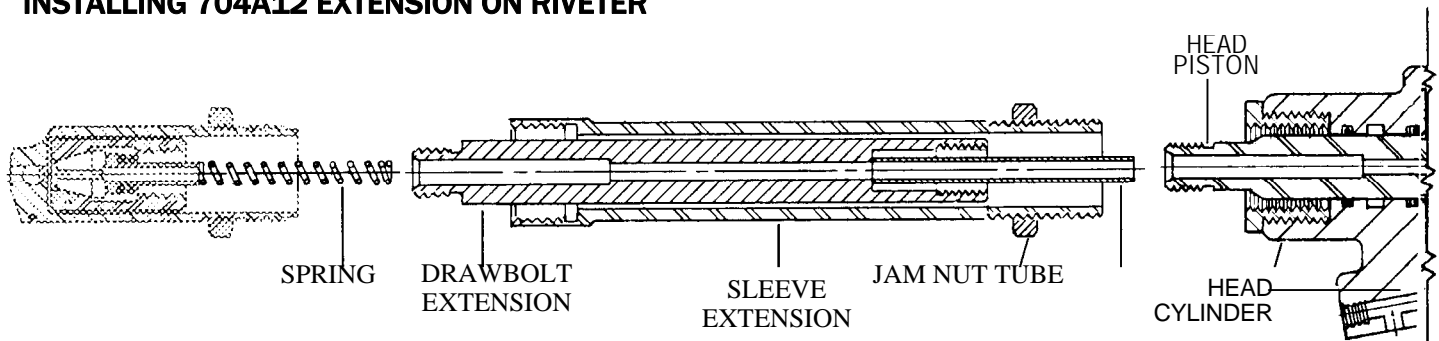

1. Insert tube into head piston to replace spring when extending an H701B-456 pulling head.
2. Screw drawbolt extension onto end of head piston. Tighten securely using wrenches on flats provided.
3. Thread sleeve extension snugly into end of head cylinder until threads bottom.
4. Tighten jam nut securely.
5. Install CherryMAX® pulling head per instructions on appropriate tool sheet.



CHERRY®
AEROSPACE

TS-704A12 Rev: A Date: 02/05/07 CR: 07-0097

1224 East Warner Ave,
Santa Ana, CA 92705
Tel: 1-714-545-5511
www.cherryaerospace.com

704A12

CHERRYMAX® EXTENSIONS

INSTRUCTION SHEET

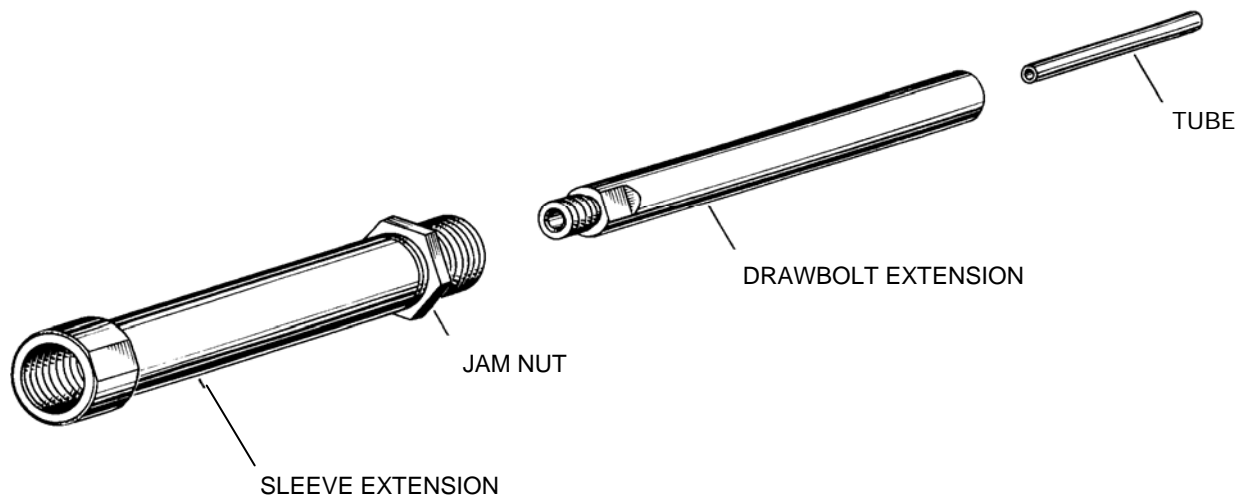

MAINTENANCE AND REPAIR

Make certain the extension is kept clean, especially the inner portion of the tube and drawbolt extension as sealants, chips, or adhesives will clog up the stem ejection passage.

DESCRIPTION	QTY. REQ.	EXTENSION NUMBER			
		704A12-2	704A12-4	704A12-6	704A12-12
Sleeve Extension	1	704B14-2	704B14-4	704B17-6	704B17-12
Jam Nut	1	671A16	671A16	671A16	671A16
Drawbolt Extension	1	704B13-2	704B13-4	704B16-6	704B16-12
Tube	1	704A15	704A15	704A15	704A15

WARRANTY

Seller warrants the goods conform to applicable specifications and drawings and will be manufactured and inspected according to generally accepted practices of companies manufacturing industrial or aerospace fasteners. In the event of any breach of the foregoing warranty, Buyer's sole remedy shall be to return defective goods (after receiving authorization from Seller) for replacement or refund of the purchase price, at the Seller's option. Seller agrees to any freight costs in connection with the return of any defective goods, but any costs relating to removal of the defective or nonconforming goods or installation of replacement goods shall be Buyer's responsibility. SELLER'S WARRANTY DOES NOT APPLY WHEN ANY PHYSICAL OR CHEMICAL CHANGE IN THE FORM OF THE PRODUCT IS MADE BY BUYER. THE FOREGOING EXPRESS WARRANTY AND REMEDY ARE EXCLUSIVE AND ARE IN LIEU OF ALL OTHER WARRANTIES AND REMEDIES; ANY IMPLIED WARRANTY AS TO QUALITY, FITNESS FOR PURPOSE, OR MERCHANTABILITY IS HEREBY SPECIFICALLY DISCLAIMED AND EXCLUDED BY SELLER. This warranty is void if seller is not notified in writing of any rejection of the goods within ninety (90) days after receipt of the goods by buyer.

Seller shall not be liable under any circumstances for incidental, special or consequential damages arising in whole or in part from any breach by Seller, AND SUCH INCIDENTAL, SPECIAL, OR CONSEQUENTIAL DAMAGES ARE HEREBY EXPRESSLY EXCLUDED.

Our policy is one of continuous development. Specifications shown in this document may be subject to changes introduced after publication.

NOTE: The properties, strength, dimensions, installed characteristics and all other information in these materials are for guidance only to aid in the correct selection of the products described herein and is not intended or implied as part of the above warranty. All applications should be evaluated for functional stability and available samples of the described parts can be requested for installed tests, suitability and evaluations.

For more information please contact our Technical Services Department at tel. 714-850-6022



CHERRY®
AEROSPACE