

GH-780

Pneumatic Power Riveter

MAINTENANCE MANUAL

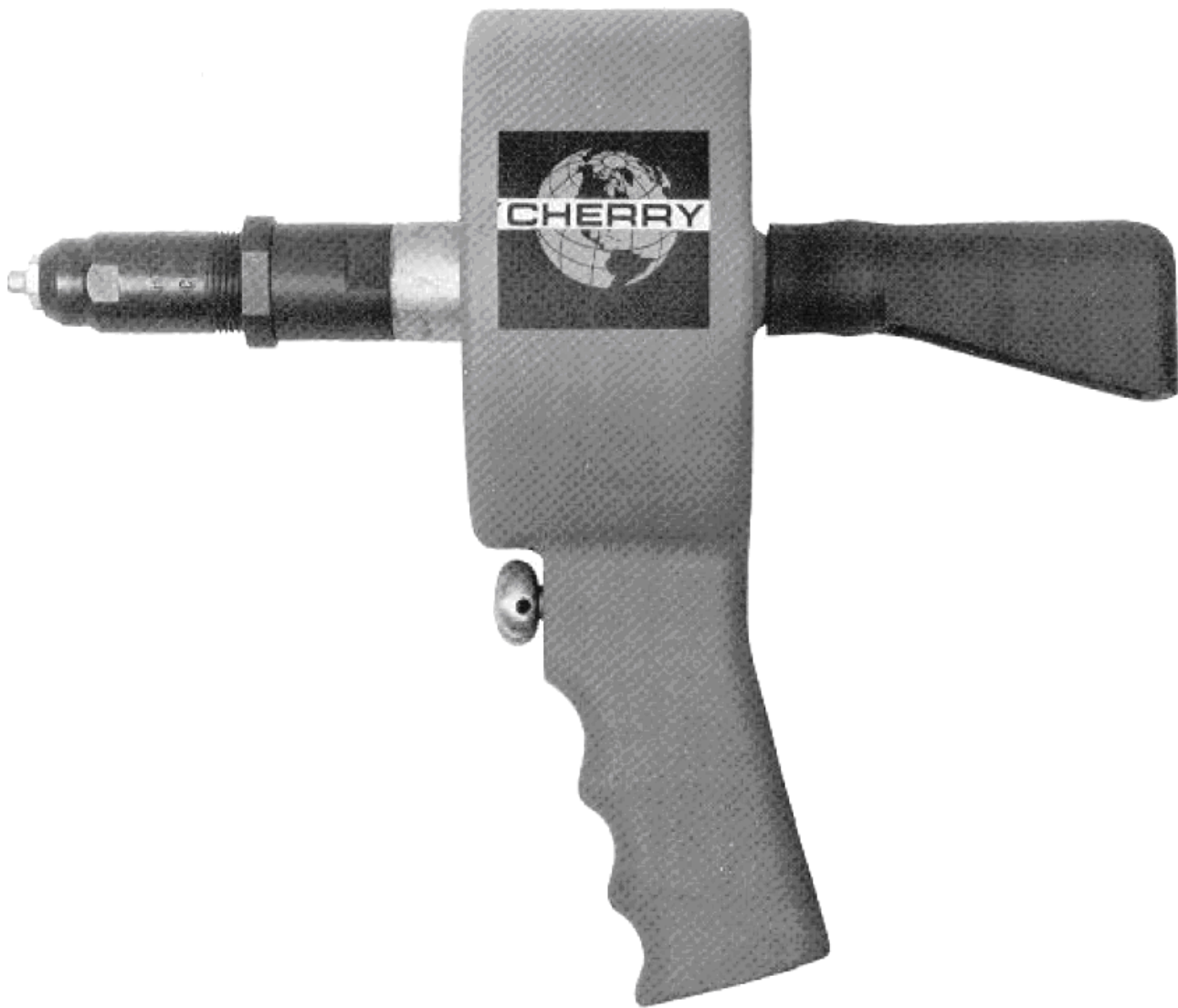

CHERRY[®]
AEROSPACE

1224 East Warner Ave,
Santa Ana, CA 92705
Tel: 1-714-545-5511
Fax: 1-714-850-6093
www.cherryaerospace.com

THE GH-780 POWER RIVETER

TABLE OF CONTENTS

Description	3
Specifications for GH-780.....	3
Safety Warnings.....	3
How to use the GH-780	4
Maintenance and Repair	4
Trouble Shooting.....	4
Overhaul.....	4
Air Valve	4
Housing	5
H703 & H743A Pulling Heads	5
Cross Sectional Drawing of GH-780 Power Riveter	6
Parts List for the GH-780 Power Riveter.....	7
Exploded View of GH-780	7
Limited Warranty	Back Cover

DESCRIPTION

The Cherry® GH-780 is a pneumatic tool designed specifically for the most efficient installation of Commercial fasteners. It weighs only 3 pounds and can be operated in any position with one hand.

SPECIFICATIONS FOR GH-780

Cherry® Aerospace's policy is one of continuous development. Specifications shown in this document may be subject to change which may be introduced after publication. For the latest information always consult Cherry® Aerospace.

AIR PRESSURE	90 PSI (6,2 bar) Min./120 PSI (8,3 bar) Max.
STROKE	1.125" (28,6 mm)
PULLING FORCE	1100 lbs. (4,95 kN) @ 90 PSI (6,2 bar)
CYCLE TIME	Approximately One Second
WEIGHT*	2.9 Pounds (1,32 kg)
NOISE LEVEL	65 Db (A)
VIBRATION	Less than 2,5 m/s ²
AIR CONSUMPTION	0.10 SCF/cycle (2,83 L/cycle)

*without pulling head

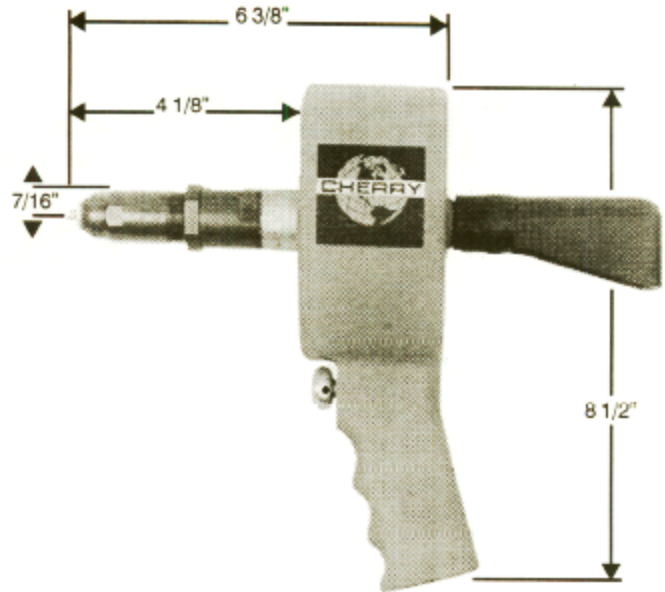

SAFETY WARNINGS

- Operating this tool with a damaged or missing stem deflector, or using the deflector as a handle, may result in severe personal injury. The pin deflector should be rotated until the aperture is facing away from the operator and other persons working in the vicinity.
- Approved eye protection should be worn when operating, repairing, or overhauling this tool.
- Do not use beyond the design intent.
- Do not use substitute components for repair.
- Any modification to the tool, pulling heads, accessories or any component supplied by Cherry® Aerospace, or their representatives, shall be the customer's entire responsibility. Cherry® Aerospace will be pleased to advise on **any proposed modification**.
- The tool must be maintained in a safe working condition at all times and examined at regular intervals for damage.
- Before disassembling the tool for repair, refer to the maintenance instructions. All repairs shall be undertaken only by personnel trained in Cherry® Aerospace installation tools. **Contact Cherry® Aerospace with your training requirement.**
- Always disconnect the air line from the tool inlet before attempting to service, adjust, fit or remove any accessory.
- Do not operate the tool when it is directed at any person.
- Ensure that the vent holes do not become blocked or covered and that all hoses are always in good condition.
- Operating air pressure should not exceed 120 psi (7,6 bar)
- Do not operate the tool without pulling head in place.
- Do not operate the tool unless the nose plate (4) is fully secured by the retaining ring (3).
- All retaining rings, screwed end caps, air fittings, hoses, hose fittings, trigger valves and pulling heads should be attached securely and examined at the end of each working shift.
- Do not pull fasteners in the air.
- The precautions to be used when using this tool must be explained by the customer to all operators. **Any question regarding the correct operation of the tool and operator safety should be directed to Cherry® Aerospace.**
- Do not pound on the rear of the tool head to force fasteners into holes as this will damage the tool.

HOW TO USE THE GH-780

Attach the proper pulling head securely to the GH780 (see Pulling Heads, page 5). Insert the rivet stem into the pulling head until the head of the rivet is in contact with the pulling head sleeve. This will ensure full engagement between the jaws and the rivet stem and will prevent slippage.

MAINTENANCE AND REPAIR

The GH-780 has been manufactured to give maximum service with minimum care. In order that this may be accomplished, the following recommendations should be followed.

1. Keep excessive moisture and dirt out of air supply to prevent wear.

TROUBLESHOOTING

1. Air line pressure should be maintained at 90 to 120 psi at the riveter. The air line should be equipped with a filter to keep excessive moisture and dirt out of the air supply. This will prevent clogging of the ports in the air valve spool and sleeve.
2. All pulling head parts should be firmly attached. Loose parts will affect the performance of the tool.
3. If riveter cycles slowly, the cause is usually insufficient air pressure. Check it with the pressure gauge. It must be 90 to 120 psi. If air pressure is sufficient, the tool should be cleaned out to remove any dirt which may be blocking the air passages. Another cause of slow cycling could be lack of lubricant on the O-rings. See the overhaul section.
4. Air exhaust is from the bottom of the handle. If air escapes from the front or rear of the tool, the O-rings are either worn or damaged and should be replaced.
5. If the tool appears to have excessive recoil motion, the air pressure is probably too high. Check with a pressure gauge, and if it is over 120 psi, it should be reduced. Too much air pressure can adversely affect the O-rings.

OVERHAUL

The disassembly and re-assembly procedures can be accomplished by utilizing the following instructions and the drawings on pages 6 and 7. **Use extreme care during disassembly and re-assembly not to mar, nick or burr any smooth**

AIR VALVE

- To disassemble, first disconnect tool from its air source.
- Remove the trigger (14) and retaining ring (16). Next, remove Level-seal plug (19). The valve spool can then be pushed out, from front to rear. The valve sleeve is pressed into the housing and should not be removed. If ports in the sleeve appear to be clogged, dip the handle in a solvent and blow air into it to free any accumulation of oil and dirt.
- Re-assembly of the air valve begins with new O-rings (17) on the valve spool (18). Lubricate with a clear grease such as Parker O-Lube, then insert into the handle of housing

Insert the rivet into the application and pull the trigger to activate the tool. Upon release of the trigger, the stem will release to the rear of the tool. Ensure that the pin deflector (12) is in place. To prevent FOD (foreign object debris), use a mandrel catcher bag (13). (Must be ordered separately).

2. Do not pound on the rear of the tool head to force rivets into holes, as this will damage the tool.
3. Make sure the pulling head is correctly and securely attached.

6. If the tool does not set rivets correctly, the trouble may be in the pulling head rather than the riveter. It may be due to worn jaws or a weak jaw spring. See the pulling head section.

Virtually all the moving parts in this tool ride on O-rings. This means no metal to metal wear. By the use of close tolerances and low micro-inch surfaces against which the O-rings seal, a long life can be expected before any overhaul becomes necessary. At that time, a complete overhaul can be achieved by the use of Service Kits G780KS, which contains a complete set of O-rings.

G780KS SERVICE KIT		
QTY	PART NO.	ITEM
1	670B31	Rod, Piston
3	P-293	O-Ring
1	P-507	O-Ring
2	P-508	O-Ring
1	P-534	O-Ring
1	TMAN GH-780	Parts List & Manual

surface that comes in contact with O-rings. Before installing O-rings, be sure to apply an O-ring lubricant such as Parker O-Lube to the surface.

from the rear. Use care not to damage O-rings by keeping them centered. Push in as far as possible until the small diameter of the valve spool comes out of the front.

- Next, using Teflon tape or pipe joint compound on threads, insert a Level-seal plug (19) and tighten firmly. The retaining ring (16) is put into the groove of the small diameter of the valve spool (18) and then the trigger (14) is put on the small diameter of the valve spool and tightened with an allen wrench on the set screw (15).

HOUSING

- Disconnect riveter from the air line and remove the pulling head before attempting disassembly of housing. If piston rod (1) turns with pulling head, hold it by applying open-end wrench to flats on end of rod.
- Remove retaining ring (3) using narrow bladed screwdriver. Rubber deflector (12) should also be removed.
- Insert a steel bar approximately 1/2" diameter by about four inches long through the rear opening until it is solidly against the end of the drawbolt (9). Strike the end of the steel bar with a hammer, using sufficient force to drive the entire nose plate/piston assembly out of the housing.
- Check rubber cushion (10) and replace if it is flattened thinner than the recess in the piston. Examine all O-rings for wear or damage and replace where necessary. O-rings (5, 8 & 6-rear) are easily replaced, but to replace the O-ring (6-front) in the nose plate (4), further disassembly of the nose plate/piston assembly is necessary. Insert a 5/16" hex

key into the end of the drawbolt (9) and then place the key securely in a vise.

- Apply an open-end wrench to the flat of the piston rod (1) and exert enough force to break the Loctite 271 seal between the piston rod (1) and the drawbolt (9). With the piston rod removed from the nose plate (4), the O-ring (6-front) may be removed. When re-assembling this unit, be sure to apply Loctite 271 to the threads on the drawbolt (9) and tighten securely.
- Re-assembly begins with inserting the two O-rings (6), followed by the O-ring (8) on the piston and the O-ring (5) on the nose plate. All O-rings must be lubricated with a clear grease such as Parker O-Lube. Exercise care when installing nose plate/piston assembly back into housing, being certain to press evenly to avoid pinching the O-rings. Push the nose plate in until it bottoms on the casting ridge, exposing the groove to permit insertion of retaining ring (3).

H703 & H743A PULLING HEADS

1. Connect the tool to its air supply and without depressing the trigger, place jaw spring (9) over tube (10) as shown and insert as far as possible into the head position.
2. Place jaws (2) into collet (6). Screw this assembly onto the head piston, making sure the tapered end of the jaw follower (3) is properly aligned in bevel in the back end of the jaws (2).
3. Thread nosepiece (1) completely into sleeve (4) and place this assembly over the collet and jaw assembly. Screw the sleeve (4) into the end of the head body while depressing the trigger, and tighten snugly.
4. Tighten jam-nut (11) securely.
5. These pulling heads will give long life if properly maintained. This includes keeping the head clean and dry, and all the parts securely tightened. The only lubrication required is a little grease such as Lubriplate 630-A inside the cone of the collet to assure a sliding action against the back of the jaws.
6. In case of damage or wear to pulling head parts, dismantle and replace with parts selected from the list below.

H743A WITH 3-PIECE JAWS

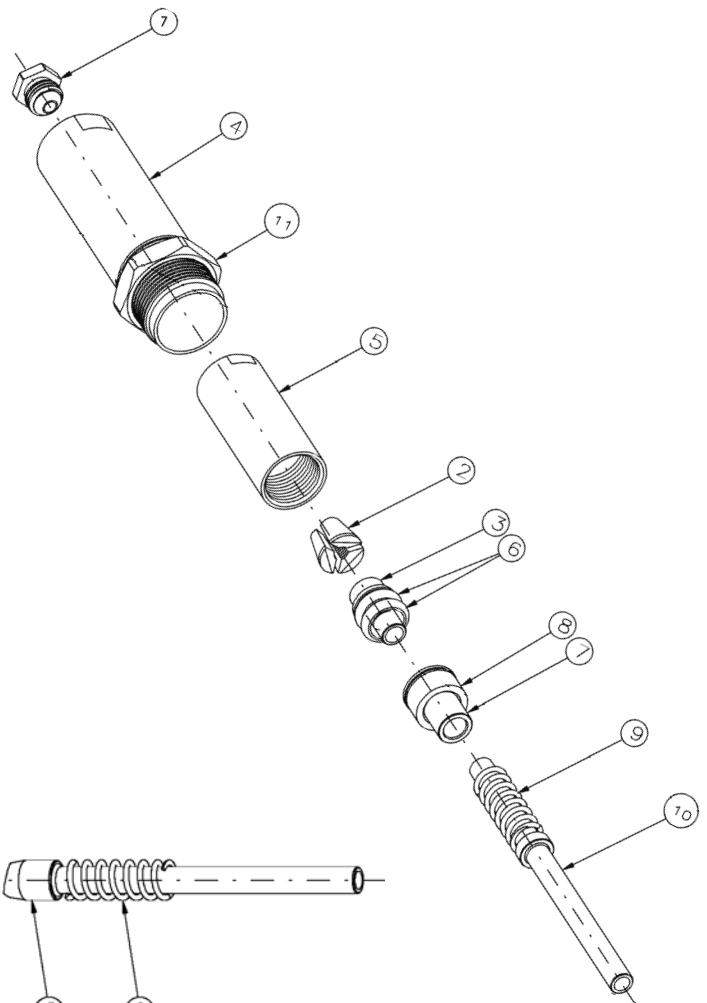

H703

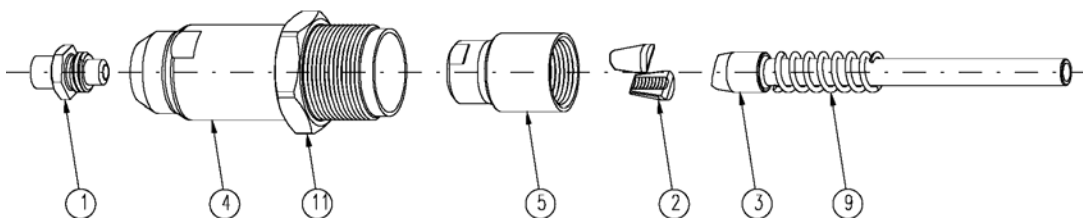

REF. NO.	QTY. REQ.	PART NUMBER FOR TWO PULLING HEADS —		RIVET DIAM.	COMMERCIAL FASTENER TYPE				
		H703	*H743A		N RIVET	Q RIVET	CherryMate RIVET	Monobolt RIVET	KlumpTite RIVET
1	1	*728A9-3Z	—	3/32	ALL	—	—	—	—
		728A9-4	—		—	—	—	—	—
		628A9-4	—		ALL	ALL	—	—	—
		*728A9-104	—	5/32	AAP,BSP, SSP	AAA,BSP, SSP	—	—	—
		728A9-4	—	3/16	—	—	ALL	—	—
		728A9-6	*743A7-5C6Z		AAP, BSP	AAP	—	—	—
		—	*743B35		—	—	—	BAPV	—
		—	*743C53		—	—	—	—	ALL
728A9-6	*743A7-5C6Z	1/4	—	—	BALM, BSLM	—	—		
4	1	703B7	*743B91	SLEEVE					
11	1	743A18	*743A18	JAM NUT					
5	1	703A8	*743B92	COLLET					
2	1 SET	728B4 (2 PC)	*743C55 (3 PC)	JAWS					
3	1	743A8-8Z	*743B93	JAW FOLLOWER					
6	2	—	*P-1195	O-RING					
8	1	—	*743A95	CUSHION					
7	1	—	*743B94	SPRING FOLLOWER					
9	1	732A8	*732A8	JAW SPRING					
10	1	—	*743A14-8Z	EJECTOR TUBE					

* MUST BE ORDERED SEPARATELY.

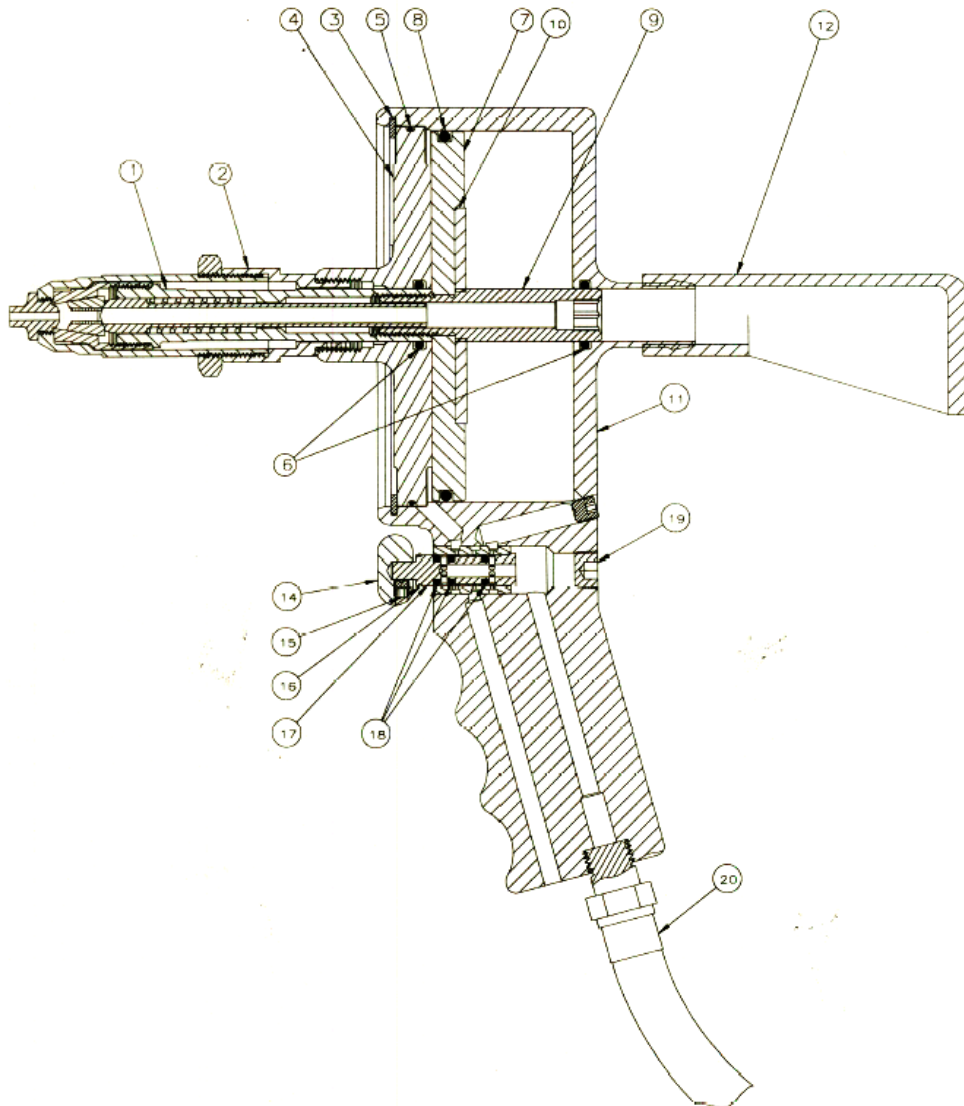

PARTS LIST FOR THE GH-780 POWER RIVETER

ITEM NO.	PART NO.	DESCRIPTION	QTY
780C1 Sub-Assembly, Riveter			
1	670B31	Rod, Piston	1
2	670B32	Sleeve	1
3	P-1290	Ring, Retaining	1
4	670B2	Plate, Nose	1
5	P-507	O-Ring (3.879, 3.739, .070)	1
6	P-508	O-Ring (.755, .549, .103)	2
7	670B3	Piston	1
8	P-534	O-Ring (4.012, 3.734, .139)	1
9	670A33	Drawbolt	1
10	670A21	Cushion	1

ITEM NO.	PART NO.	DESCRIPTION	QTY
780C1 Sub-Assembly, Riveter			
11	670C4	Housing	1
12	530A16	Deflector	1
13	*670A20	Mandrel Catcher Bag	1
14	670A7	Trigger	1
15	P-510	Screw, Soc Hd Set, 8-32 x 3/16	1
16	P-295	Ring, Retaining	1
17	620A79	Spool, Valve	1
18	P-293	O-Ring (.316, .176, .070)	3
19	P-698	Plug, Pipe	1
20	*P-948	Hose	1

*Furnished only on special order

EXPLODED VIEW OF GH-780

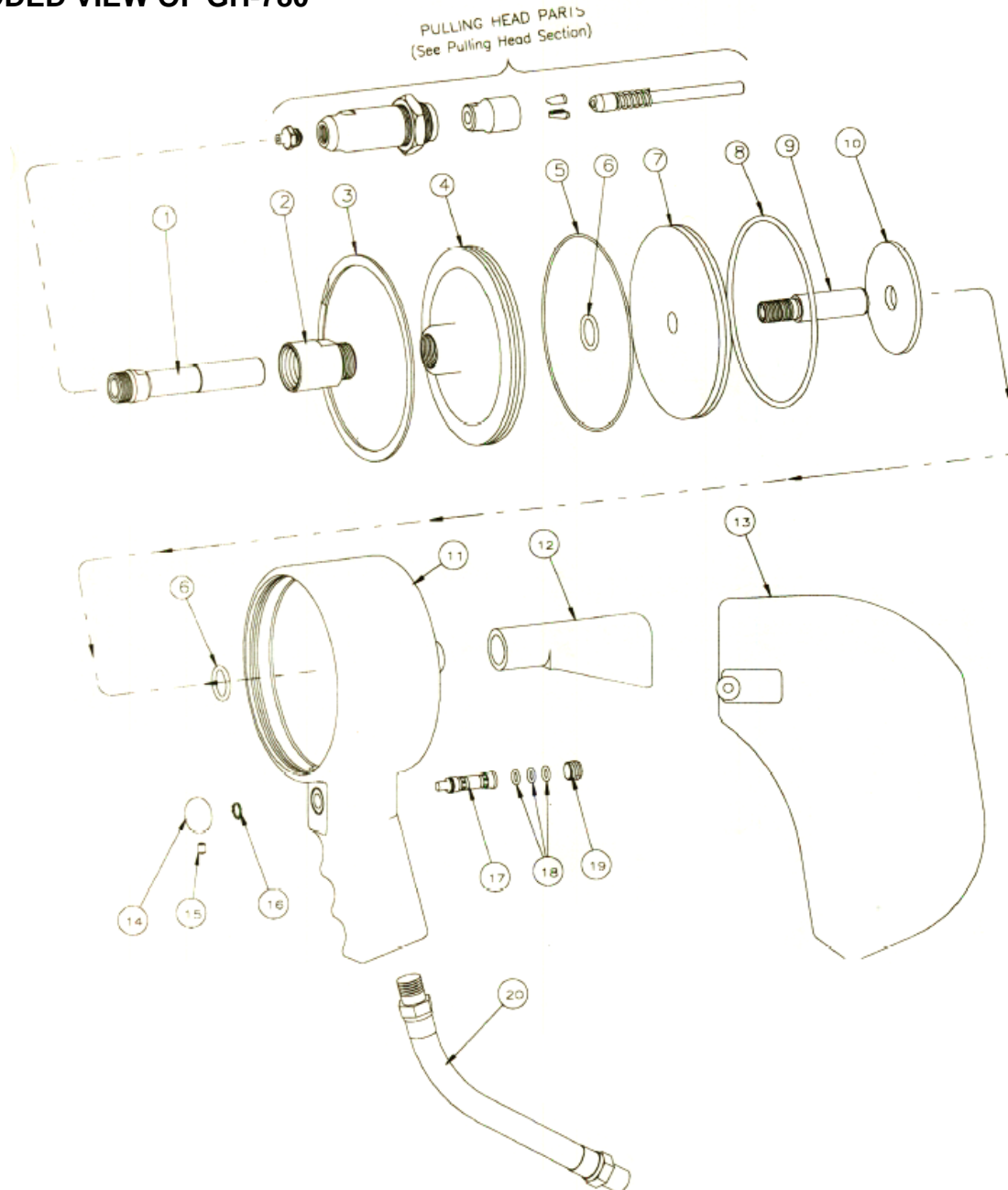

WARRANTY

Seller warrants the goods conform to applicable specifications and drawings and will be manufactured and inspected according to generally accepted practices of companies manufacturing industrial or aerospace fasteners. In the event of any breach of the foregoing warranty, Buyer's sole remedy shall be to return defective goods (after receiving authorization from Seller) for replacement or refund of the purchase price, at the Seller's option. Seller agrees to any freight costs in connection with the return of any defective goods, but any costs relating to removal of the defective or nonconforming goods or installation of replacement goods shall be Buyer's responsibility. SELLER'S WARRANTY DOES NOT APPLY WHEN ANY PHYSICAL OR CHEMICAL CHANGE IN THE FORM OF THE PRODUCT IS MADE BY BUYER.

THE FOREGOING EXPRESS WARRANTY AND REMEDY ARE EXCLUSIVE AND ARE IN LIEU OF ALL OTHER WARRANTIES AND REMEDIES; ANY IMPLIED WARRANTY AS TO QUALITY, FITNESS FOR PURPOSE, OR MERCHANTABILITY IS HEREBY SPECIFICALLY DISCLAIMED AND EXCLUDED BY SELLER. THIS WARRANTY IS VOID IF SELLER IS NOT NOTIFIED IN WRITING OF ANY REJECTION OF THE GOODS WITHIN ONE (1) YEAR AFTER INITIAL USE BY BUYER OF ANY POWER RIVETER OR NINETY (90) DAYS AFTER INITIAL USE OF ANY OTHER PRODUCT.

Seller shall not be liable under any circumstances for incidental, special or consequential damages arising in whole or in part from any breach by Seller, AND SUCH INCIDENTAL, SPECIAL, OR CONSEQUENTIAL DAMAGES ARE HEREBY EXPRESSLY EXCLUDED.

For more information please contact our Technical Services Department at Tel. 714-850-6022

*LOCTITE® is a registered trademark of Henkel Corporation
DEXRON® is a registered trademark of GM corporation.
PARKER® is a trademark of Parker Hannifin Corporation
LUBRRIPLATE® is a trademark of Fiske Brothers Refining Co.*



CHERRY®
AEROSPACE

1224 East Warner Ave,
Santa Ana, CA 92705
Tel: 1-714-545-5511
Fax: 1-714-850-6093
www.cherryaerospace.com