

GH-703

Power Riveter

MAINTENANCE MANUAL

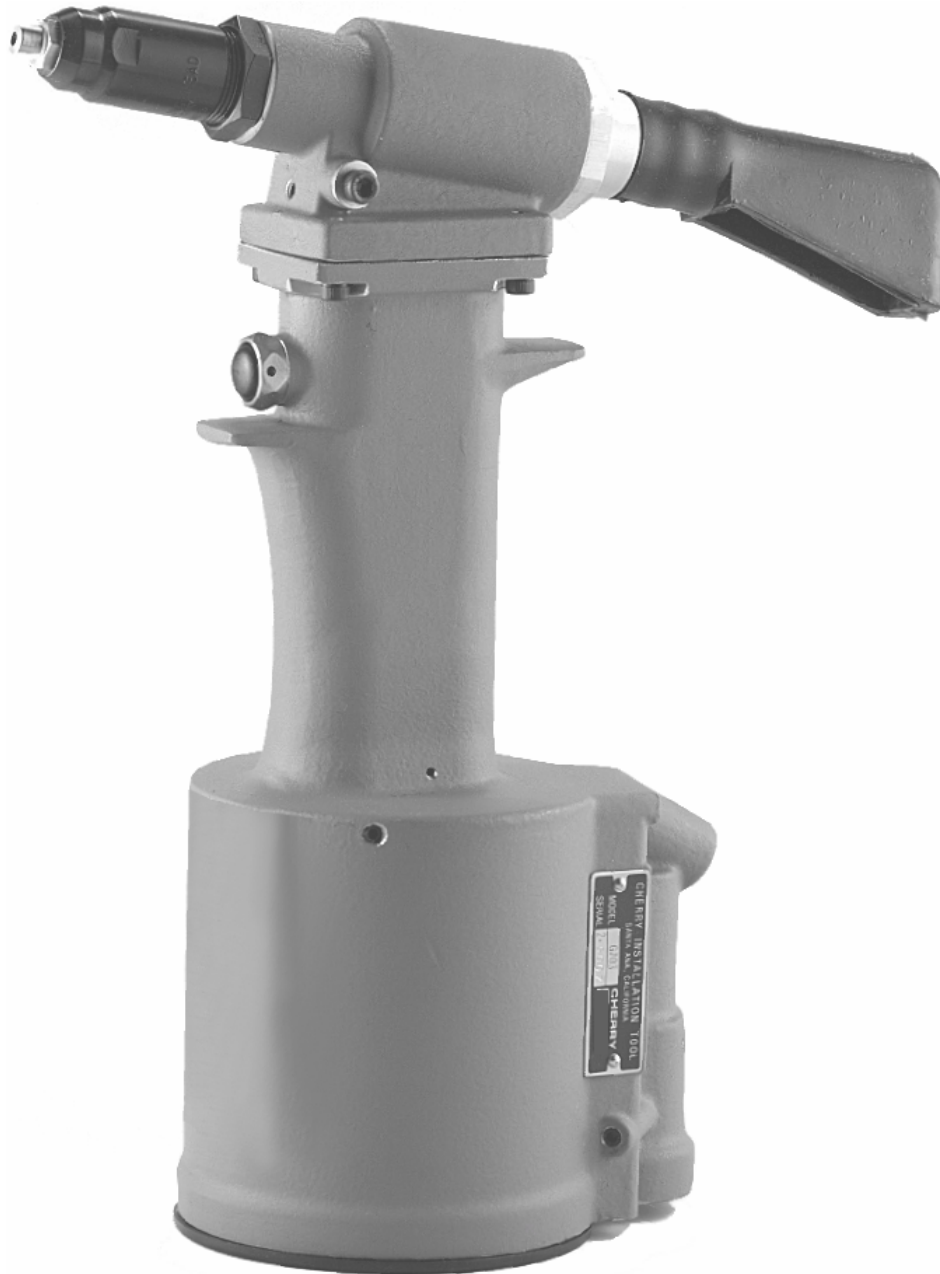

CHERRY[®]
AEROSPACE

1224 East Warner Ave,
Santa Ana, CA 92705
Tel: 1-714-545-5511
Fax: 1-714-850-6093
www.cherryaerospace.com

G H-703

Power Riveter

The Cherry® GH-703 is a pneumatic-hydraulic tool designed specifically for the most efficient installation of commercial fasteners. It weighs only 5 pounds and can be operated in any position with one hand. It has a full 3/4" rivet setting stroke and a rated pull load of 2000 pounds.

The GH-703 riveter operates on a wide range of air pressure, with 90 to 120 psi providing the maximum efficiency. At 90 lbs. air pressure, the GH-703 has a decibel rating of 80dB(A) and consumes 3 CFM at 20 cycles per minute.

A mandrel catcher bag may be attached to eliminate costly cleanup.

The GH-703 comes equipped with nose-piece 728A9-6 to set:

- N Rivets - 3/16" diameter
- Q Rivets - 3/16" diameter
- Cherrymate® Rivets - 1/4" diameter

There is also a spare nosepiece, 728A9-4, included for setting:

- N Rivets - 1/8" diameter
- Q Rivets - 1/8" diameter
- Cherrymate® Rivets - 3/16" diameter

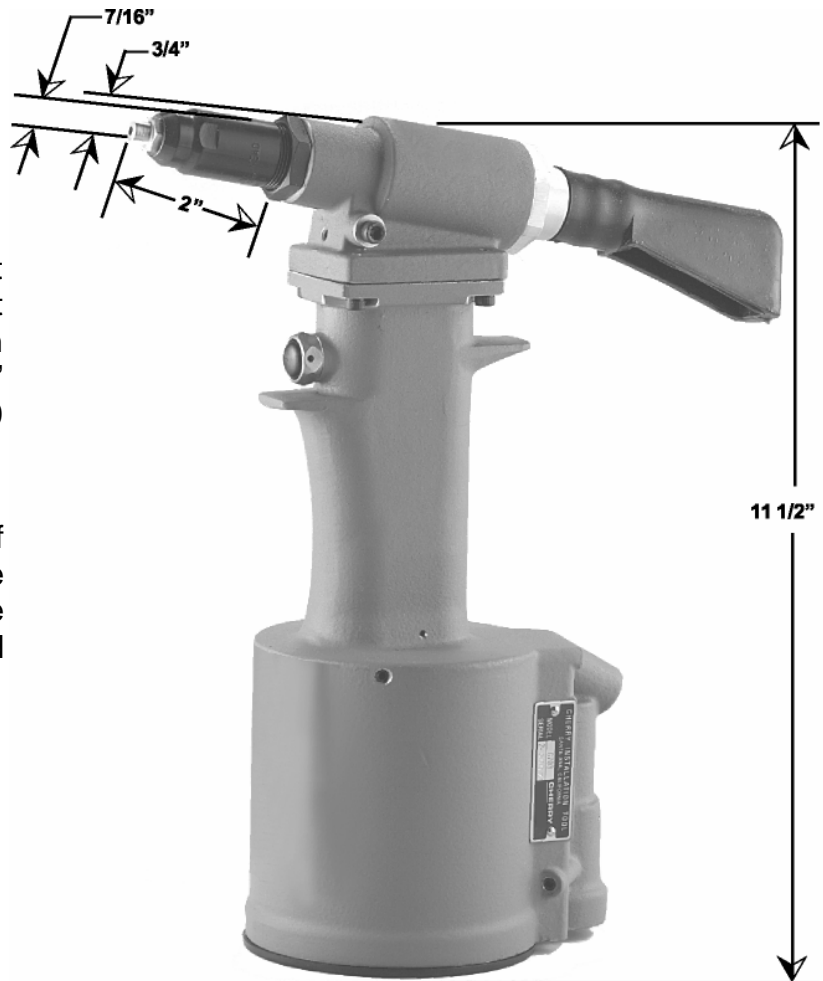

Warning: Approved eye protection should be worn when operating, repairing, or overhauling this tool.

MANY OTHER STYLES AND SIZES OF COMMERCIAL RIVETS CAN BE SET WITH THIS TOOL. REFER TO THE NOSEPIECE SELECTION CHART ON PAGE 8 FOR APPLICABLE PART NUMBERS.

How the GH-703 Operates

When the tool is pressurized by hooking up to an air line, the valve spool is forced upward. This movement aligns the port in the spool with the lower port within the handle, allowing air pressure to enter the bottom port of the power air cylinder. This forces the air piston upward.

When the trigger is depressed, air bleeds out from behind the trigger, lowering air pressure against the bottom of the spool. Air pressure is now greater on top of the spool, forcing it down. This action shuts off the air path to the bottom of the power air cylinder, and simultaneously opens the upper port, allowing pressure to enter directly into the top of the air cylinder. This forces the air piston downward.

The air piston is connected to the hydraulic power piston with a common connecting rod. When the

air piston is activated by changes in the air valve, it in turn activates the hydraulic power piston. Air pressure also travels up through a port in the handle to enter the rear of the head cylinder. This air pressure forces the return of the head piston to its full forward position.

The center area of the handle (that part held by the hand during riveting) contains the hydraulic system. The hydraulic power piston has its own cylinder containing the fluid which is pressurized by the downward travel of the piston. This forces the fluid up through the handle into the front of the head cylinder, thereby exerting the force needed to push the head piston back in a full 3/4" rivet setting stroke. This same fluid then returns to the power cylinder by the forward action of the head piston under air pressure.

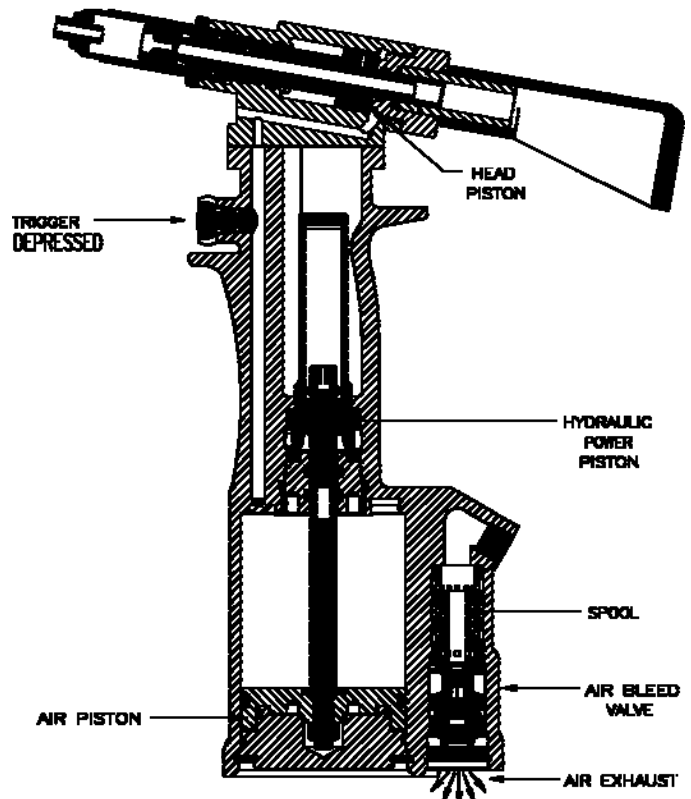
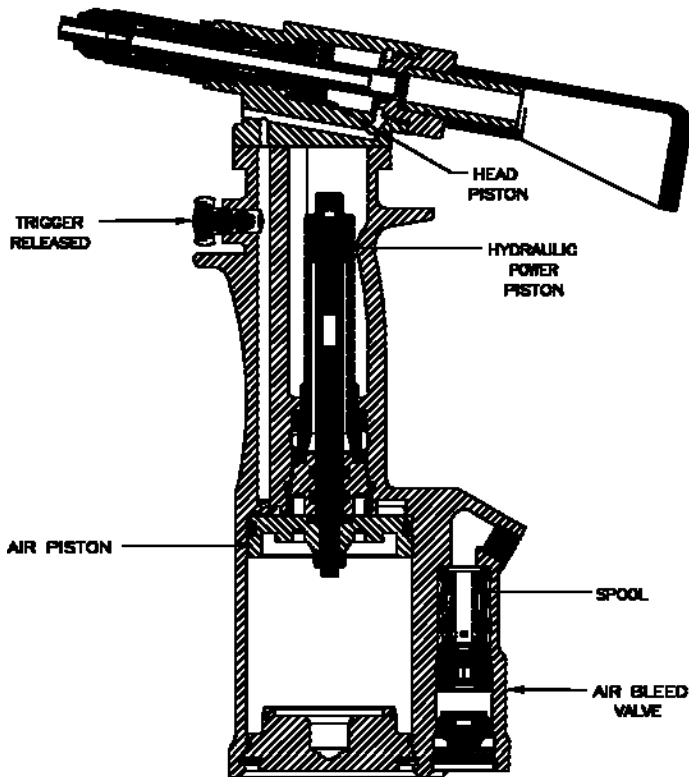

SPECIFICATIONS ARE SUBJECT TO CHANGE WITHOUT NOTICE.

PART LIST FOR GH-703 RIVETER			
REF. NO.	PART NUMBER	DESCRIPTION	QTY. REQ.
1	703C2	703C2 HEAD CYLINDER	1
2	P722	O-RING,(.816,.676,.070)	2
3	P860	BACK-UP RING, (.794,.688,.053)	1
4	703B3	HEAD PISTON	1
5	P872	O-RING,(1.130,.924,.103)	1
6	P868	BACK-UP RING, (1.129,.957,.103)	1
7	P724	O-RING, (1.129,.898,.070)	2
8	P112	O-RING,(.504,.364,.070)	2
9	703A5	SEAL TUBE	1
10	P109	RETAINING RING (EXT. .375 DIA)	2
11	703B4	CAP	1
12	P880	RETAINING RING (NON-STANDARD)	1
13	703A13	DEFLECTOR FITTING	1
14	530A16	DEFLECTOR PIN	1
15	P126	WASHER	1
16	P90	BUTTON HEAD SOC. SCREW, 10-32 X .375 LG	1
17	P838	O-RING, (.568,.362,.103)	2
18	P115	BACK-UP RING,(.551,.375,.088)	2
19	P727	O-RING,(1.318,1.112,.103)	1
20	700B93	PACKING PLUG	1
21	P731	BACK-UP RING,(3.365,3.125,.120)	2
22	P730	QUAD RING,(3.387,3.109,.139)	1
62	700A115	AIR PISTON SUB-ASSY.	
23	700A110	WASHER, AIR PISTON	1
24	700C106	AIR PISTON	1
25	700A111	WASHER, AIR PISTON	1
26	P737	CONELOCK NUT	1
27	P725	O-RING,(3.129,2.989,.070)	1
28	700C112	HANDLE BASE	1
29	P735	RETAINING RING, (INT. 3.500 DIA)	1
30	700B109	BASE COVER	1
31	P736	RETAINING RING,(EXT. 2.250 DIA)	1
32	703A33	TRIGGER ASSEMBLY	1
33	P223	O-RING,(.285,.145,.070)	1
34	703A11	HANDLE	1
35	P734	RETAINING RING, (.689,.599,.025)	1
36	700B7	POWER CYLINDER	1
37	P833	O-RING, (1.068,.862,.103)	2
38	P739	BACK-UP RING,(.624,.518,.053)	1
39	P294	O-RING, (.629,.489,.070)	1
63	700A8	POWER PISTON & ROD SUB- ASSY.	
40	702A11	PISTON ROD CAP	1
41	700A9	POWER PISTON	1
42	702A12	PISTON STOP	1
43	700A10	POWER PISTON ROD	1
44	P653	O-RING, (.691,.551,.070)	4
45	700B73	VALVE SLEEVE	1
46	700A67	SPRING	1
47	P829	O-RING,(.504,.364,.070)	3
64	700A15	VALVE SPOOL SUB- ASSY.	
48	700D15-2	VALVE SPOOL	1
49	700A18	FILTER	1
50	700A69	METERING SCREW	1
51	P834	O-RING, (.816,.676,.070)	2
52	700A16	VALVE PLUG	1
53	700A17	MUFFLER	1
54	P279	RETAINING RING, (INT. .906)	1
55	700A22	GASKET	1
56	P832	O-RING,(.379,.239,.070)	1
57	P27	SOC. HD. CAP SCREW, 8/32 X 1/2	4
58	*670A20	MANDREL CATCHER BAG	1
59	*P948	HOSE	1
60	*703A22	HANGER	1
61	*P881	BUTTON HEAD SOC. SCREW, 10-32 X 3/8	2

* Furnished only on special order

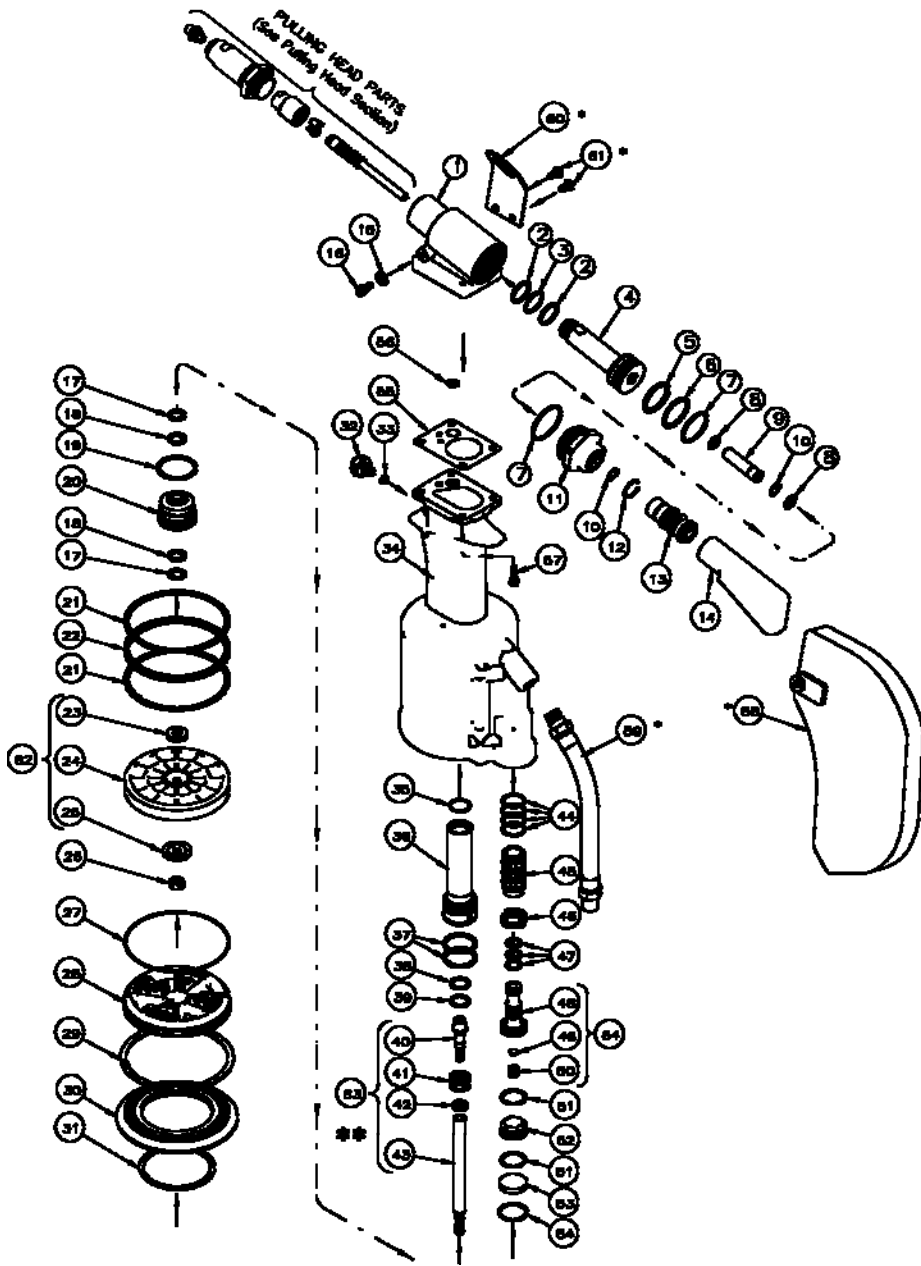

** Components can not be ordered separately. Sold as an assembly only.

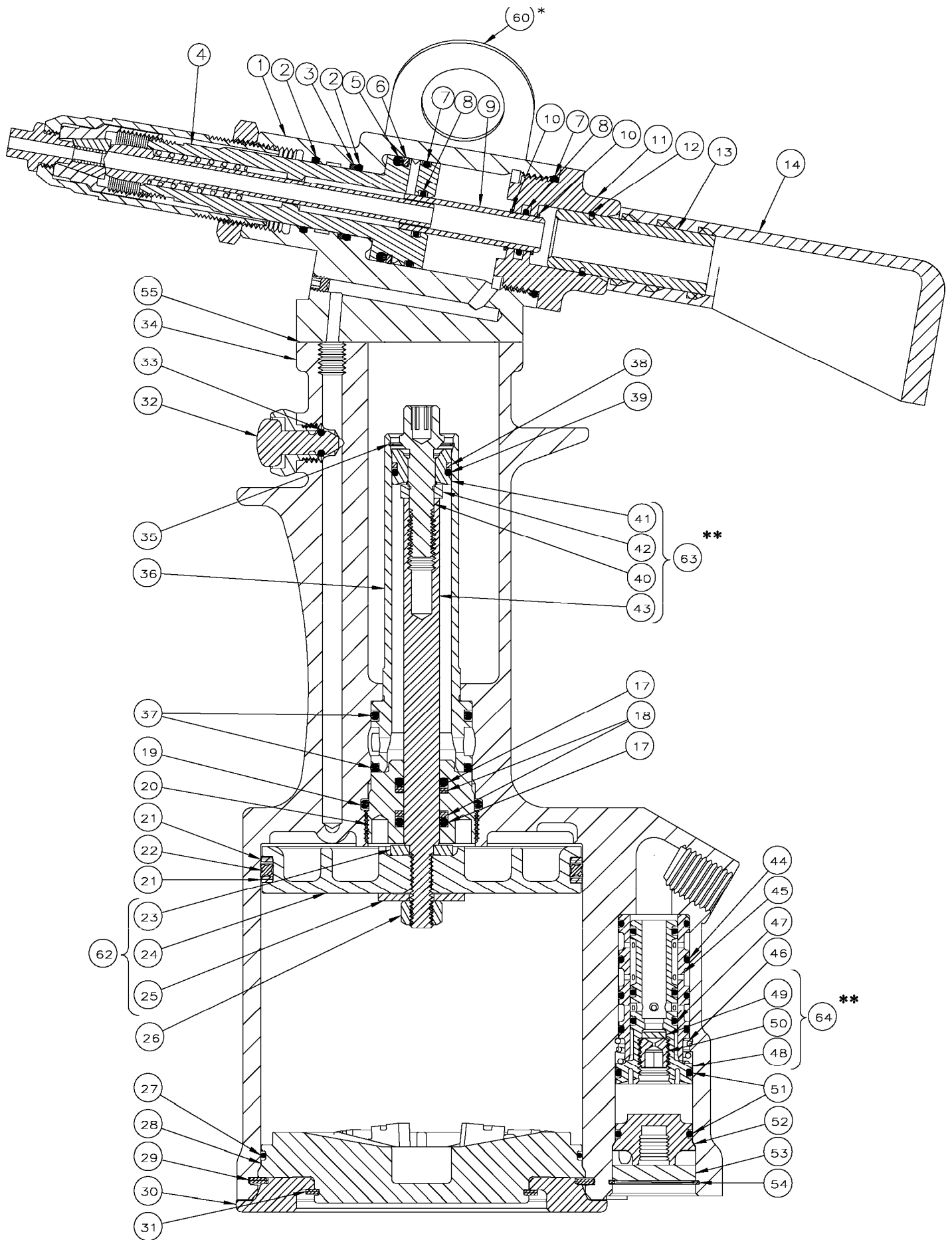

Maintenance and Repair:

The GH-703 Power Riveter has been manufactured to give maximum service with minimum care. In order that this may be accomplished, the following recommendations should be followed:

1. The hydraulic system should be full of oil and free from air at all times.
2. Keep excessive moisture and dirt out of the air supply to prevent wear.
3. Do not pound on the rear of the tool head to force rivets into holes, as this will damage the tool.
4. Make sure the pulling head is correctly and securely attached.

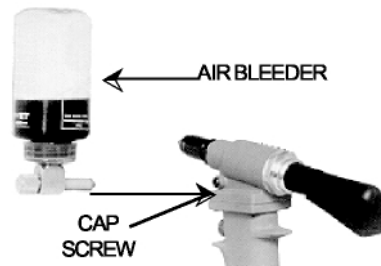

To fill riveter with oil:

1. Remove head body assembly from handle assembly.
2. Fill handle assembly with automatic transmission fluid (ATF-Dexron®) to within 1/8" of the top of the handle casting.
3. Replace head body assembly, being sure gasket (55) and O-ring (56) are properly in place. Tighten cap screws (57) uniformly to prevent leakage around gasket.
4. Connect tool to air line and cycle ten times to fully circulate hydraulic system with oil.
5. With tool connected to the air line, remove cap screw (16) being sure NOT to cycle tool. Attach Avdel® air bleeder 700A77 according to instructions included with bleeder and purge system of air by cycling the tool until oil flow is free of air bubbles.
6. Remove air bleeder and allow excess oil to drain from screw hole.
7. Reinstall cap screw (16) and Stat-O-Seal washer (15) and test tool for proper function by installing rivets.

NOTE: Steps 1 through 4 may be eliminated when replacing just a small amount of oil.

Troubleshooting:

1. Check air line for correct pressure at the tool. It must be 90 to 120 psi.
2. Check tool for lack of hydraulic fluid (see oil filling instructions).

3. Check for oil leakage.
 - a. Oil leaking around the cap screw (16) in the head indicates that the screw is loose or the washer gasket (15) needs replacing.
 - b. If oil should leak through the bypass hole at the base of the handle (34), the O-rings (18 or 37) are worn or damaged.
 - c. Oil leakage from the front of the head (1) indicates that O-rings (2) are worn or damaged.
4. Check for excessive air leakage from air bleed valve.
 - a. If spring (46) is broken or dislodged, replace per instructions on page 7.
 - b. If O-rings (51) on plug (52) are worn or damaged, replace.
 - c. If O-rings (47) on valve spool (48) are worn or damaged, replace.
5. Check movement of piston (4). If it does not move freely or is slow in operation:
 - a. O-rings (2), (5), or (7) may be damaged and require replacement.
 - b. Piston (4) may be mechanically locked due to damaged parts.
 - c. Power piston may be held off its seat on rod (43) allowing oil to bypass. Drain tool, flush thoroughly, and refill with fresh fluid.
 - d. Muffler (53) or air filter inside spool (48) may be plugged with dirt. Clean them thoroughly with normal solvent and back-blow with compressed air.
 - e. Hole in metering screw in valve spool (48) may be blocked or damaged. Hole diameter should be .028". Clear and size or replace valve spool.
6. If the tool cycles repeatedly, even though the trigger has not been pulled, it indicates that the spring (46) which holds the valve sleeve (45) is broken or dislodged. See air bleed valve instructions on page 7.
7. If the mandrel sticks in pulling head:
 - a. Pulling head components need maintenance. Disassemble pulling head, clean, and replace worn parts. Reassemble following instructions on page 8.
 - b. There may be excess oil in front of the head piston. With tool attached to air line, remove cap screw (16) and allow excess oil to run out. Replace cap screw and tighten.
 - c. The mandrels are wedged side by side in jaw follower (3) or tube (10) from failure to eject spent mandrel from tool prior to inserting next rivet. Disassemble pulling head, clear jaw follower, and reassemble following instructions on page 8.
8. If the mandrel breaks above designed breaknotch:
 - a. Jaws (2) are not seating on mandrel properly due to wear. Replace if worn.
 - b. Jaws (2) are not seating properly due to worn jaw spring. Replace if spring is less than 2" long.

Overhaul:

The disassembly and reassembly procedure can be accomplished by utilizing the following instructions and the drawings on pages 4 and 5. Use extreme care during disassembly and reassembly not to mar, nick, or burr any smooth surface that comes in contact with O-rings. Before installing O-rings, be sure to apply a good rubber lubricant, such as Lubriplate, to the surfaces. It is recommended that the special assembly tools shown here be used to facilitate the overhaul.



Virtually all of the moving parts in this tool ride on O-rings, protected by backup rings where high pressure dictates. This means no metal to metal wear. By use of close tolerances and low microinch surfaces against which the O-rings seal, a long life can be expected before any overhaul becomes necessary. At that time, a complete overhaul can be achieved by the use of Service Kit G703KS, which contains a complete set of O-rings, backup rings, screws, washers, and gaskets.

Air Bleed Valve:

To disassemble, first disconnect the tool from its air source. Remove retaining ring (54) and muffler (53). Insert a 5/16-18 threaded rod or bolt into end of valve plug (52) and pull it out. Using the same procedure, pull out spool (48).

NOTE: It should never be necessary to remove valve sleeve (45) unless the ports in the sleeve are plugged up tightly from contaminated air. The O-rings on this sleeve are static and hence do not wear. If it is suspected that the ports are plugged up, use needle nose pliers to grasp end of spring (46), turning clockwise and pulling to dislodge from groove in casting. With spring removed, valve sleeve (45) can be pulled out using an 837B10 valve sleeve removal tool.

To reassemble, reverse the above procedure, being certain that all O-rings are properly lubricated before installation. The spring (46) is best installed using an 836B10 spring inserting tool to push the large diameter coil into the casting groove. This requires care, as the tool will not operate if this spring is not anchored firmly.

Handle:

To inspect the air cylinder bore, remove only parts 27 through 31. Any further disassembly will require removal of the head assembly first.

For this complete disassembly, start by removing parts 27 through 31. Next, holding tool upright, remove four socket-head cap screws (57). Lift head assembly from handle (34) and set aside O-ring (56) and gasket (55). Empty all hydraulic fluid into a container by pouring from the handle.

Place piston rod wrench 700A61 down into top of handle, onto the hex head of the power piston (63). While holding this wrench, remove the conelok nut (26) using a 7/16" socket wrench. Still holding piston rod wrench, remove the air piston (24) using packing plug wrench 700B65, by turning counterclockwise. When the air piston is completely freed from the piston rod, tap or push on the piston rod wrench to eject piston from the bottom of the handle.

After the removal of the air piston, slide piston rod (63) back up to the end of its travel. Using the packing plug wrench remove packing plug (20). It may be necessary to hold the handle upside down in a vise while loosening the packing plug. With packing plug removed, the power cylinder (36) can be tapped out by lowering the power cylinder tool down into the top of the handle onto the top of the cylinder. The O-rings and backup rings (17 & 18) are best removed (and replaced) by using a thin, bent hook. Care must be taken to avoid damaging the O-ring grooves or cylinder.

Head:

Always remove the complete pulling head from the tool before attempting disassembly of head body.

Remove end cap (11). Seal tube (9) comes out with cap as it is held in place by two retaining rings (10). These need not be removed.

Push against threaded end of head piston (4) to slide it out of head body (1). Be careful not to damage threads or cause burrs on polished piston rod surface. O-rings (2) and backup ring (3) can now be removed using a bent hook. O-rings (8) can be removed in the same manner.

Upon reassembly, be sure to install O-rings and backup rings carefully to avoid cutting them. Also, always lubricate any O-rings with Lubriplate. The reassembly sequence is the opposite of disassembly. This includes filling the handle (34) with hydraulic fluid before replacing gasket (55) and O-ring (56), just prior to replacing head assembly. (See oil filling instructions.)

Tighten the four socket-head cap screws (57) uniformly to prevent leakage around the gasket. When assembled, purge the system of air by using Avdel Cherry air bleeder 700A77 according to instructions included with bleeder. (See oil filling instructions.)

Installing the H703 and H743A Pulling Heads

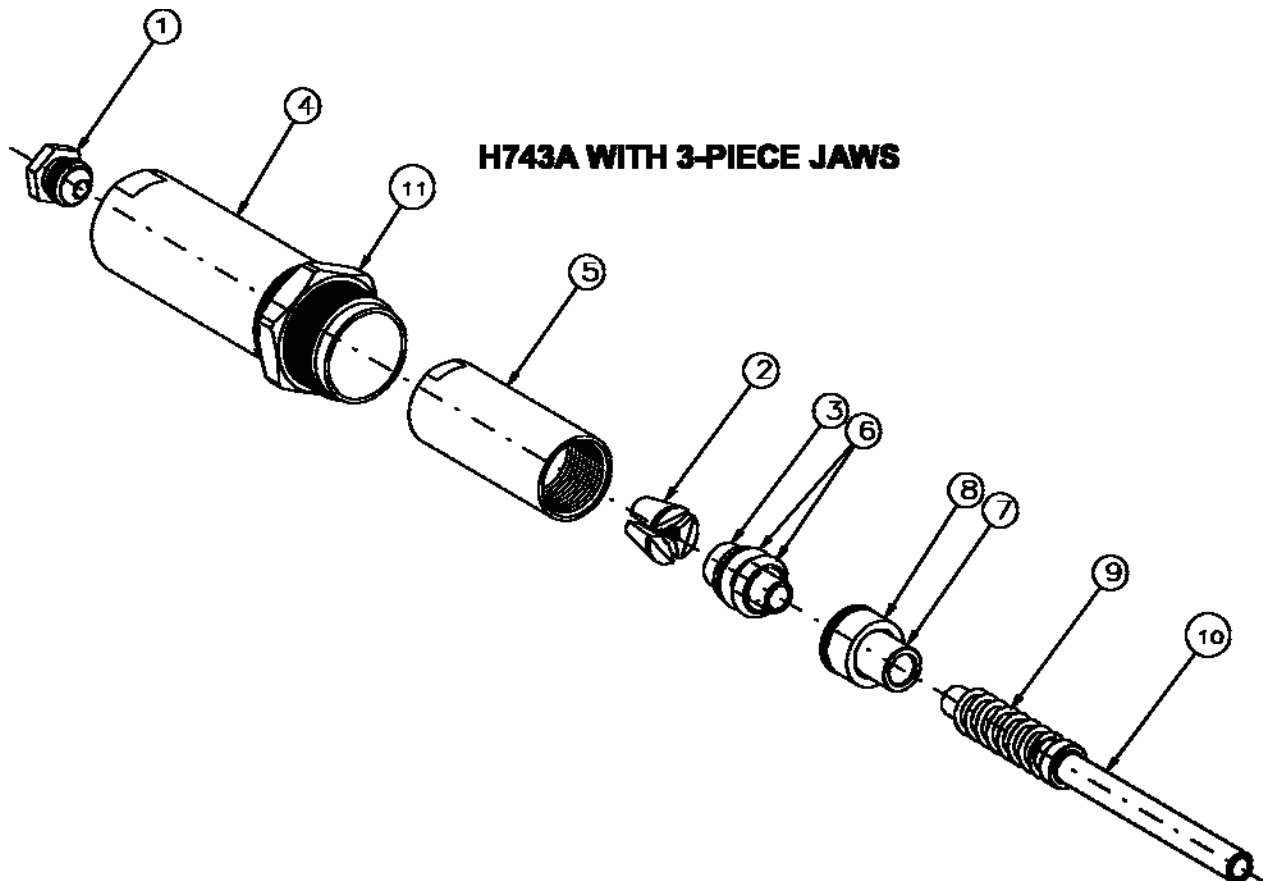
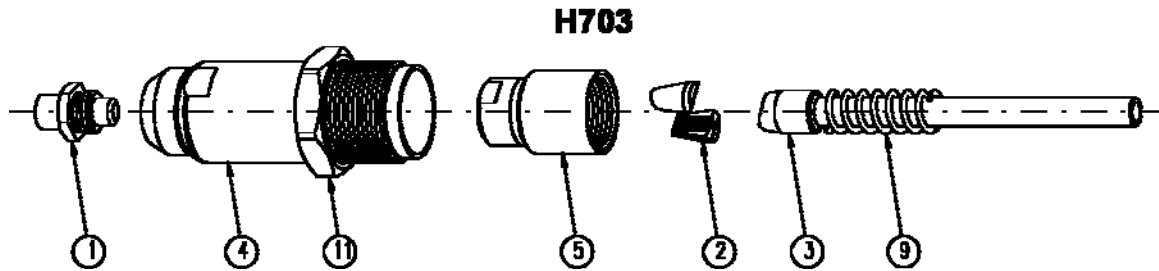

1. Connect the tool to the air supply. Without depressing the trigger, place spring (9) over tube (10 or 3) as shown, and insert as far as possible into head piston.
2. H743A. Place jaws (2) inside collet (5). Place 2 O-rings (6) over jaw follower (3) and cushion (8) over spring follower (7). Assemble jaw follower (3) and spring follower (7) and insert into collet (5). Screw this assembly onto the head piston, making sure the tapered end of the jaw follower (3) is properly aligned in the bevel in the back end of the jaws (2).
3. Thread nosepiece (1) completely into sleeve (4) and place (4) into end of head body while depressing the trigger. Tighten snugly.
4. Tighten jam-nut (11) securely.
5. These pulling heads will give long life if properly maintained. This includes keeping the head clean and dry and all the parts securely tightened. The only lubrication required is a little Lubriplate inside the cone of the collet to assure a sliding action against the back of the jaws.
6. In case of damage or wear to pulling head parts, dismantle and replace with parts selected from the following list.

REF. NO.	QTY, REQD	NOSEPIECE PART NUMBER USING LISTED PULLING HEADS		RIVET DIAM.	COMMERCIAL FASTENER TYPE							
					N RIVET	Q RIVET	C-M RIVET	T RIVET	MONO BOLT	KT RIVET	G RIVET	
		H703	H743A									
1	1	*728A93Z	—	3/32	ALL	—	—	—	—	—	—	—
		728A9-4	—	7/8	ALL	ALL	—	—	—	—	—	—
		*728A9-704	—	5/32	ALL	ALL	—	—	—	—	—	—
		728A9-4	—	3/16	—	—	ALL	—	—	—	—	—
		728A9-6	*743A7-5C6Z		ALL	ALL	—	—	—	—	—	—
		*703A25-6T	*703A25-6T		—	—	—	BSPT	—	—	—	—
		*703A25-6TA	*703A25-6TA		—	—	—	BAPTS	—	—	—	—
		—	*743B35A		—	—	—	—	ALL	—	—	ALL
		—	*743053		—	—	—	—	—	ALL (2)	—	—
		728A9-6	*743A7-5C6Z	1/4	—	—	ALL	—	—	—	—	—
		—	*743A7-8Z		(7)	(3)	—	—	—	—	—	—
		—	*743A25-8TA		—	—	—	BAPTS	—	—	—	—
		—	*743B32A		—	—	—	—	BAPV	—	—	BAPG
		—	*743051		—	—	—	—	—	ALL(2)	—	—

REF. NO.	QTY. REQD.	PART NUMBER FOR LISTED PULLING HEADS		DESCRIPTION
		H703	*H743A	
4	1	703B7	743B91	SLEEVE
11	1	743A18	743A18	JAM NUT
5	1	703A8	743B92	COLLET
2	1(SET)	728B4(2PC)	743C55(3PC)	JAWS
3	1	743A8-8Z	743B93	JAW FOLLOWER
6	2	—	P1195	O-RING
8	1	—	743A95	CUSHION
7	1	—	743B94	SPRING FOLLOWER
9	1	732A8	732A8	JAW SPRING
10	1	—	743A14-8Z	EJECTION TUBE

- (1) AAP AND BSP.
- (2) REQUIRES TWO PULLING STROKES TO SET RIVET.
- (3) AAPQ and BSPQ.

*MUST BE ORDERED SEPARATELY.

WARRANTY

Seller warrants the goods conform to applicable specifications and drawings and will be manufactured and inspected according to generally accepted practices of companies manufacturing industrial or aerospace fasteners. In the event of any breach of the foregoing warranty, Buyer's sole remedy shall be to return defective goods (after receiving authorization from Seller) for replacement or refund of the purchase price, at the Seller's option. Seller agrees to any freight costs in connection with the return of any defective goods, but any costs relating to removal of the defective or nonconforming goods or installation of replacement goods shall be Buyer's responsibility. SELLER'S WARRANTY DOES NOT APPLY WHEN ANY PHYSICAL OR CHEMICAL CHANGE IN THE FORM OF THE PRODUCT IS MADE BY BUYER.

THE FOREGOING EXPRESS WARRANTY AND REMEDY ARE EXCLUSIVE AND ARE IN LIEU OF ALL OTHER WARRANTIES AND REMEDIES; ANY IMPLIED WARRANTY AS TO QUALITY, FITNESS FOR PURPOSE, OR MERCHANTABILITY IS HEREBY SPECIFICALLY DISCLAIMED AND EXCLUDED BY SELLER. THIS WARRANTY IS VOID IF SELLER IS NOT NOTIFIED IN WRITING OF ANY REJECTION OF THE GOODS WITHIN ONE (1) YEAR AFTER INITIAL USE BY BUYER OF ANY POWER RIVETER OR NINETY (90) DAYS AFTER INITIAL USE OF ANY OTHER PRODUCT.

Seller shall not be liable under any circumstances for incidental, special or consequential damages arising in whole or in part from any breach by Seller, AND SUCH INCIDENTAL, SPECIAL, OR CONSEQUENTIAL DAMAGES ARE HEREBY EXPRESSLY EXCLUDED.

For more information please contact our Technical Services Department at Tel. 714-850-6022

*LOCTITE® is a registered trademark of Henkel Corporation
DEXRON® is a registered trademark of GM corporation.
PARKER® is a trademark of Parker Hannifin Corporation
LUBRRIPLATE® is a trademark of Fiske Brothers Refining Co.*



CHERRY®
AEROSPACE

1224 East Warner Ave,
Santa Ana, Ca 92705
Tel: 1-714-545-5511
Fax: 1-714-850-6093
www.cherryaerospace.com