

GH-4024 HAND RIVETER

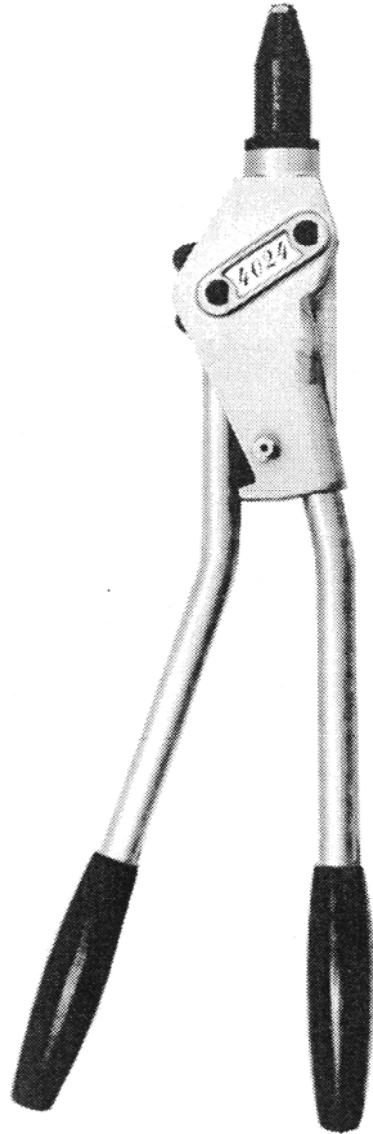

OPERATING MAINTENANCE MANUAL



CHERRY®
AEROSPACE

1224 East Warner Ave,
Santa Ana, CA 92705
Tel: 1-714-545-5511
Fax: 1-714-850-6093
www.cherryaerospace.com

GH-4024 **Hand Riveter**

The GH-4024 is a medium duty, manually operated blind rivet setting tool weighing only 2 1/2 pounds. This rivet setting tool is designed to set high strength 3/16" and 1/4" diameter commercial rivets and is ideally suited for low production environments, on the job site installations, and prototype laboratory work where compressed air is not available.

The GH-4024 comes equipped with nosepiece 743A7-8C to set:

- N Rivets - 1/4" diameter
- Q Rivets - 1/4" diameter

There is also a spare nosepiece, 743A7-5C62, included for setting:

- N Rivets - 3/16" diameter
- Q Rivets - 3/16" diameter
- Cherrymate - 1/4" diameter

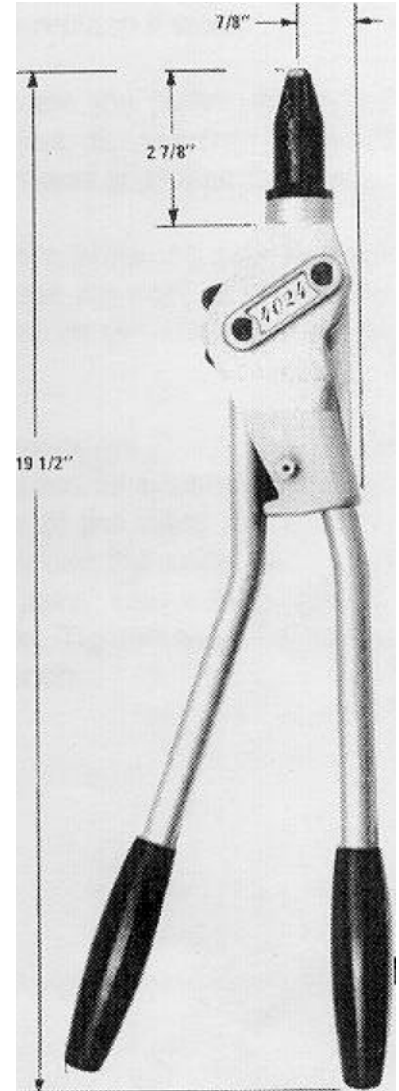

ADDITIONAL NOSEPIECES CAN BE OBTAINED WHICH WOULD ALLOW THE USER TO SET HIGH STRENGTH MONOBOLT® RIVETS. CONTACT YOUR CHERRY® REPRESENTATIVE OR WRITE THE FACTORY TECHNICAL SERVICES DEPARTMENT FOR APPLICABLE PART NUMBERS.

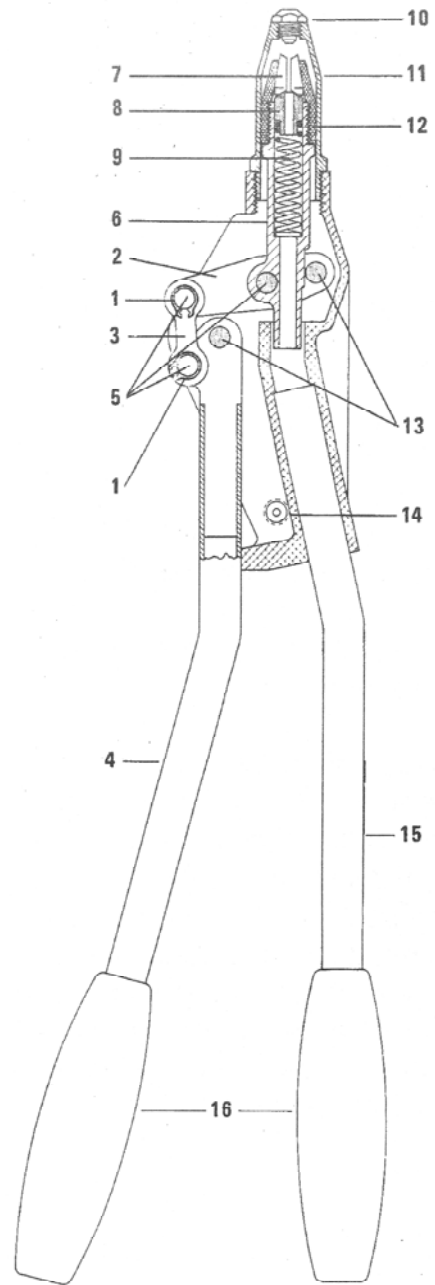
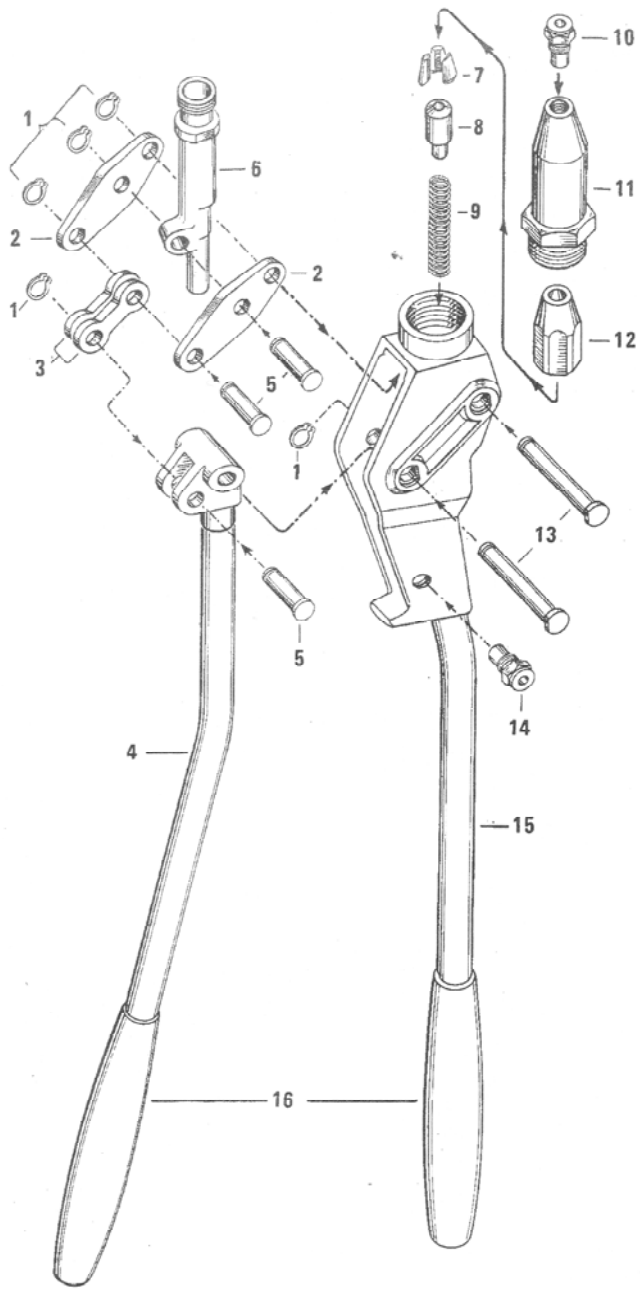

REF. NUMBER	PART NUMBER	DESCRIPTION	QTY. REQUIRED	REF. NUMBER	PART NUMBER	DESCRIPTION	QTY. REQ.
1	25-11	Circlip	5	9	66-23	Spring	1
2	25-13	Lever	2	10	743A7-8c	Nosepiece, 1/4"	1
3	25-14	Link	2	11	66-16	Nose Body	1
4	25-5	Moving Handle	1	12	66-17	Jaw Case	1
5	25-15	Pivot Pin - Short	3	13	25-19	Pivot Pin - Long	2
6	25-10	Drawbolt	1	14	743A7-5C6Z	Nosepiece, 3/16"	1
7	743B54	Jaws (3 pcs)	1 set	15	25-3	Body Assembly	1
8	25-8	Jaw Pusher	1	16	25-20	Grip	2

Operation:

The GH-4024 Riveter has one fixed and one movable handle. Prior to beginning the setting operation, the movable handle must be opened to its outmost position to inset the rivet mandrel into the pulling head. The rivet should then be placed into the application with the riveter nosepiece held squarely against the head of the rivet.

Setting of the rivet will begin as the movable handle is closed towards the stationary handle. Thereafter as the handle is opened for each stroke, the tool will back away from the application until the jaw case advances far enough to open the jaws and release the mandrel. The nosepiece should then be repositioned squarely against the head of the rivet prior to the beginning of the next setting stroke.

Should the setting force of the rivet, with the movable handle of the tool fully opened exceed the capability of the operator, or be of a nature as to cause injury to the operator, the distance between the handles can be reduced by positioning the nosepiece slightly away from the rivet head (not against), prior to the beginning of the setting stroke. Doing this will position the handles closer together, giving the operator a greater leverage advantage and reducing the closure distance when the mandrel breaks.

Troubleshooting:

1. If the mandrel will not enter the pulling head with the handles fully extended, the tool is probably contaminated with dirt or metal chips. Dismantle the pulling head (7-12), clean with a solvent, examine jaw teeth for signs of wear and replace if worn.
2. If the mandrel enters the pulling head but does not grip the rivet, disassemble as above and check for worn jaws or a weak jaw spring.
3. If the mandrel enters, grips and sets the rivet but does not release the rivet, disassemble as above and check for dirt, weak jaw spring or worn jaws.
4. Pulling head components (7-12) should be clean and dry. The only lubrication necessary is on the outside of the jaws to assure a sliding action between the collet taper and the backs of the jaws. Use a clear grease such as Lubriplate®. Tighten all components snugly with a wrench

WARRANTY

Seller warrants the goods conform to applicable specifications and drawings and will be manufactured and inspected according to generally accepted practices of companies manufacturing industrial or aerospace fasteners. In the event of any breach of the foregoing warranty, Buyer's sole remedy shall be to return defective goods (after receiving authorization from Seller) for replacement or refund of the purchase price, at the Seller's option. Seller agrees to any freight costs in connection with the return of any defective goods, but any costs relating to removal of the defective or nonconforming goods or installation of replacement goods shall be Buyer's responsibility. SELLER'S WARRANTY DOES NOT APPLY WHEN ANY PHYSICAL OR CHEMICAL CHANGE IN THE FORM OF THE PRODUCT IS MADE BY BUYER.

THE FOREGOING EXPRESS WARRANTY AND REMEDY ARE EXCLUSIVE AND ARE IN LIEU OF ALL OTHER WARRANTIES AND REMEDIES; ANY IMPLIED WARRANTY AS TO QUALITY, FITNESS FOR PURPOSE, OR MERCHANTABILITY IS HEREBY SPECIFICALLY DISCLAIMED AND EXCLUDED BY SELLER. THIS WARRANTY IS VOID IF SELLER IS NOT NOTIFIED IN WRITING OF ANY REJECTION OF THE GOODS WITHIN ONE (1) YEAR AFTER INITIAL USE BY BUYER OF ANY POWER RIVETER OR NINETY (90) DAYS AFTER INITIAL USE OF ANY OTHER PRODUCT.

Seller shall not be liable under any circumstances for incidental, special or consequential damages arising in whole or in part from any breach by Seller, AND SUCH INCIDENTAL, SPECIAL, OR CONSEQUENTIAL DAMAGES ARE HEREBY EXPRESSLY EXCLUDED.

For more information please contact our Technical Services Department at Tel. 714-850-6022

LUBRIPLATE® is a registered trademark of Fiske Brothers Refining Co



CHERRY®
AEROSPACE

© 2007 Cherry Aerospace

Supplier's Federal Identification Code: 11815

1224 East Warner Ave,
Santa Ana, CA 92705
Tel: 1-714-545-5511
Fax: 1-714-850-6093
www.cherryaerospace.com

TM-GH-4024
Rev.: A
Date: 02/05/07
CR# 07-0097