

ORIGINAL INSTRUCTIONS

G715A

Pneumatic-hydraulic Riveter

MANUAL



CHERRY[®]
AEROSPACE

1224 E. Warner Ave
Santa Ana, CA 92705
www.cherryaerospace.com

DESCRIPTION

The Cherry G715A Pneumatic-Hydraulic Riveter is designed specifically for the most efficient installation of Cherry Rivets. It weighs only 4 lbs. and can be operated in any position with one hand.

The G715A Riveter is 10-5/8" high, has a 1-1/8" stroke and generates a minimum of 1400 lbs. of pull on 90 to 110 psi of air pressure at the tool. See chart on following page for tool capacity.

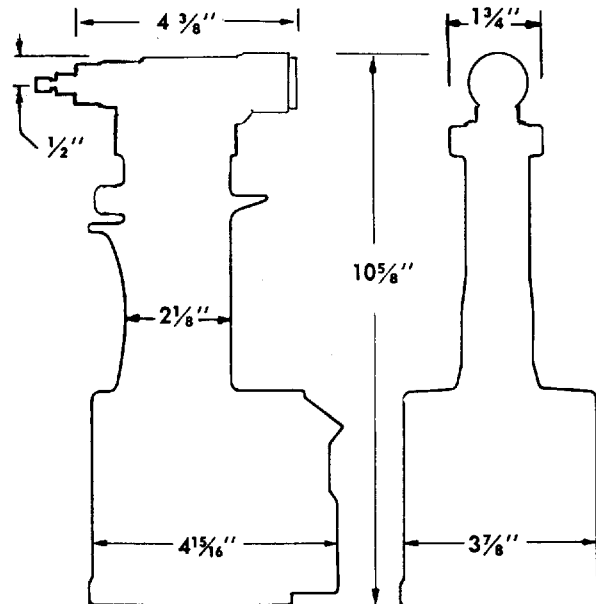

PULLING HEADS

Pulling heads are not furnished with this tool but must be ordered separately.

In ordering heads be sure to specify the shank diameter and head style (universal or countersunk) of the rivets to be installed.

The following pulling heads will fit directly on the G715A Riveter:

G6H Series For installing 100, 200, 300 and 500 Series Knob Stem Cherry Rivets.

H80 Series For 600, 700 and 800 Series High-Clinch Cherry Rivets.

H615 Series ... For 2000 Series Locked Spindle, Flush Fracturing Cherrylock Rivets.

H9015 Series . For 9000 Series Serrated Stem Cherry Rivets.

INSTALLING PULLING HEADS ON RIVETER

1. Engage threads of pulling head inside nose fitting (1) and turn head clockwise until the threads bottom out.
2. Tighten jam nut to lock pulling head in desired position.

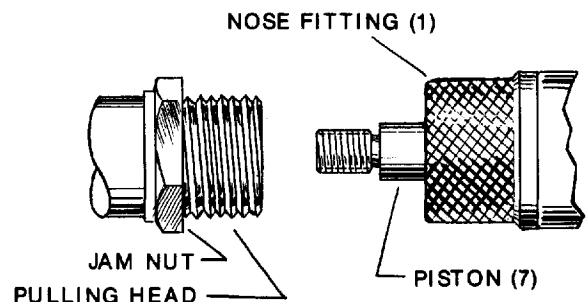

TOOL CAPACITY CHART: The numbers shown in the rivet columns below are the maximum grip length that can be installed with this tool. Dashes indicate sizes which cannot be installed in any grip length.

CHERRY RIVETER MODEL		MS STYLE CHERRY RIVETS (MS20600)									
G715A	SERRATED STEM PULLING HEAD	RIVET DIAM. *	SELF-PLUGGING				PULL-THROUGH				
			ALUM.		MONEL		ALUM.		STEEL MONEL		
			9157 9163	9156 9162	9563	9562	9117 9127	9116 9126	9517	9516	
			UNIV. HEAD	CTSK. HEAD	UNIV. HEAD	CTSK. HEAD	UNIV. HEAD	CTSK. HEAD	UNIV. HEAD	CTSK. HEAD	
	H9015	-4	ALL	ALL	ALL	ALL	ALL	ALL	ALL	ALL	ALL
		-5	ALL	ALL	-	-	ALL	ALL	-	-	
		-6	16	18	-	-	-	-	-	-	
		-8	-	-							

* Rivet diameters shown apply to either knob or serrated stem rivets. Grip lengths shown apply only to knob stem since all lengths of serrated stem rivets can be installed by cycling tool as many times as necessary.

MAINTENANCE AND REPAIR

The G715A Riveter has been manufactured to give maximum service with minimum care. In order that this may be accomplished, the following recommendations should be followed.

1. The hydraulic system should be full of oil and free from air at all times.
2. Keep excessive moisture and dirt out of the air supply to prevent wear.
3. Do not pound on the rear of the tool head to force rivets into holes as this will damage the tool.
4. Make sure the pulling head is correctly and securely attached.

2. Using a pressure oil can filled with DEXRON III Automatic Transmission Fluid, Type A (no substitute), force the fluid into the head until filled. It may be necessary to turn tool upside down to insure head is filled with fluid.
3. Replace the cap screw, cycle the trigger several times and then repeat steps 1 and 2 above.
4. To insure the positive removal of ALL air from the hydraulic system, we recommend the use of Cherry Air Bleeder No. 700A77.

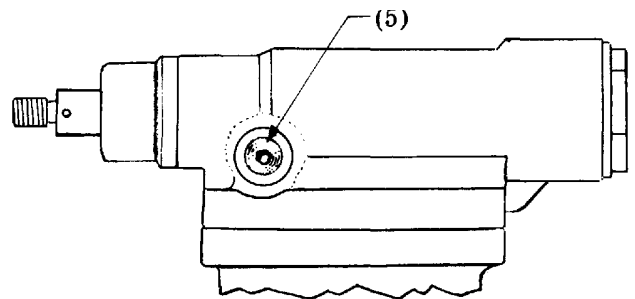

TO FILL RIVETER WITH OIL

1. Connect the tool to an air line and remove the cap screw (5) located on the side of the head.

SAFETY WARNINGS

- **Approved eye protection should be worn when operating, repairing, or overhauling this tool.**
- **Do not use beyond the design intent.**
- **Do not use substitute components for repair.**
- **Any modification to the tool, pulling heads, accessories or any component supplied by CHERRY® Aerospace, or their representatives, shall be the customer's entire responsibility.** CHERRY® Aerospace will be pleased to advise on any proposed modification.
- **The tool must be maintained in a safe working condition at all times and examined at regular intervals for damage.**
- **Before disassembling the tool for repair, refer to the maintenance instructions. All repairs shall be undertaken only by personnel trained in CHERRY® Aerospace installation tools.** Contact CHERRY® Aerospace with your training requirement.
- **Always disconnect the air line from the tool inlet before attempting to service, adjust, fit or remove any accessory.**
- **Do not operate the tool when it is directed at any person.**
- **Ensure that the vent holes do not become blocked or covered and that air line hoses are always in good condition.**
- **Excessive contact with the fluid should be avoided to minimize the possibility of rashes.** Care should be taken to wash thoroughly.
- **Operating air pressure should not exceed 110 psi (7,6 bar).**
- **Do not operate the tool without pulling head in place.**
- **Do not operate the tool unless the handle base (26) is fully secured by the base cover (28) and retaining rings (27 & 29).**
- **All retaining rings, screwed end caps, air fittings, trigger valves and pulling heads should be attached securely and examined at the end of each working shift.**
- **Do not pull rivet in the air.**
- **The precautions to be used when using this tool must be explained by the customer to all operators.** Any question regarding the correct operation of the tool and operator safety should be directed to CHERRY® Aerospace.
- **Do not pound on the rear of the tool head to force rivets into holes as this will damage the tool.**
- **Do not depress the trigger while disconnecting the air bleeder and replacing the cap screws (5) when bleeding the tool.**

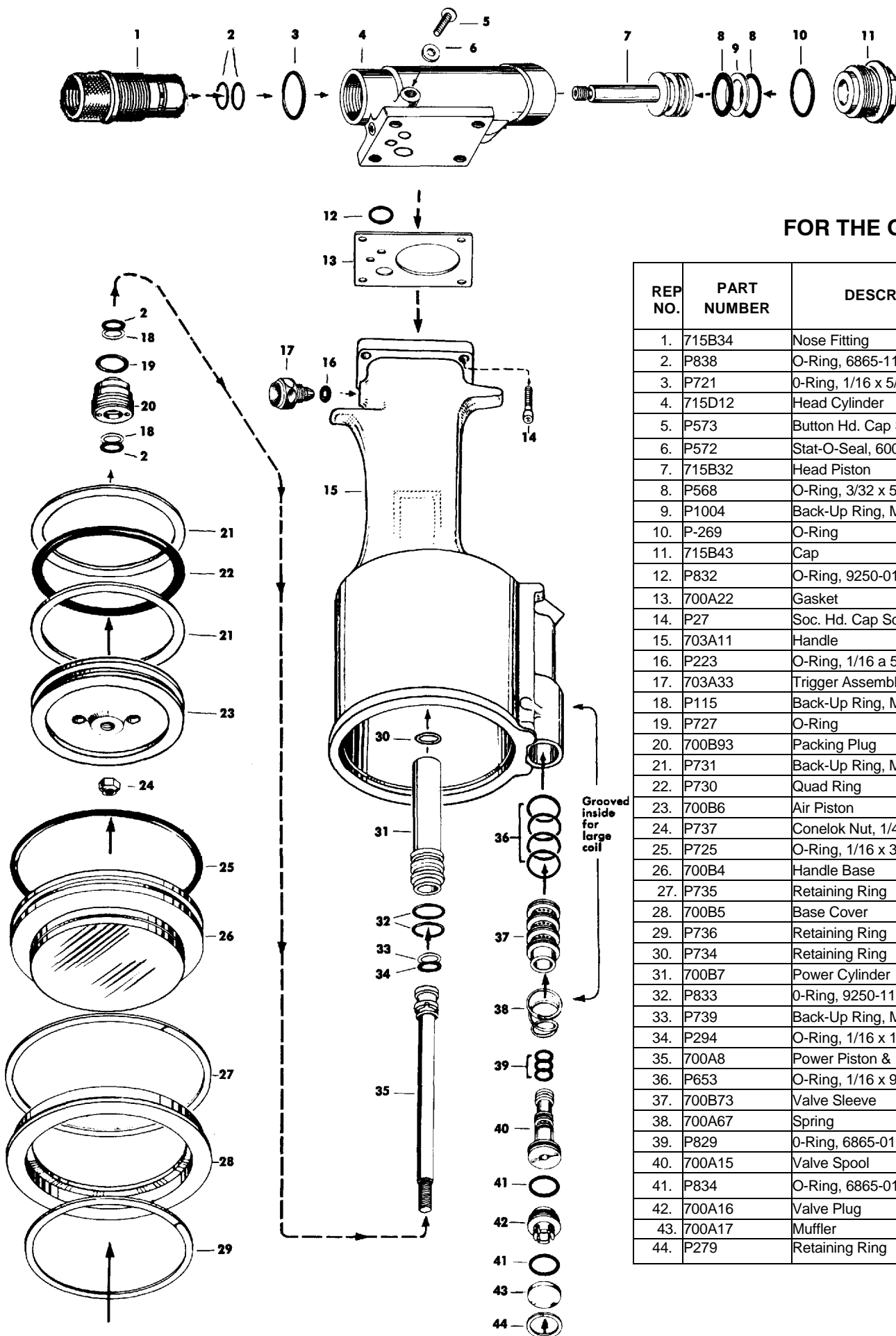

PARTS LIST FOR THE G715A RIVETER

REP NO.	PART NUMBER	DESCRIPTION	QTY. REQ.
1.	715B34	Nose Fitting	1
2.	P838	O-Ring, 6865-110 (No subs.)	4
3.	P721	O-Ring, 1/16 x 5/8 x 3/4	1
4.	715D12	Head Cylinder	1
5.	P573	Button Hd. Cap Screw	1
6.	P572	Stat-O-Seal, 600-001-10	1
7.	715B32	Head Piston	1
8.	P568	O-Ring, 3/32 x 5/8 x 13/16	2
9.	P1004	Back-Up Ring, MS28782-114	1
10.	P-269	O-Ring	1
11.	715B43	Cap	1
12.	P832	O-Ring, 9250-010 (No subs.)	1
13.	700A22	Gasket	1
14.	P27	Soc. Hd. Cap Screw, 8-32 a 1/2	4
15.	703A11	Handle	1
16.	P223	O-Ring, 1/16 a 5/32 x 9/32	1
17.	703A33	Trigger Assembly	1
18.	P115	Back-Up Ring, MS28782-8	2
19.	P727	O-Ring	1
20.	700B93	Packing Plug	1
21.	P731	Back-Up Ring, MS28783-13	2
22.	P730	Quad Ring	1
23.	700B6	Air Piston	1
24.	P737	Conelok Nut, 1/4-20	1
25.	P725	O-Ring, 1/16 x 3 x 3-1/8	1
26.	700B4	Handle Base	1
27.	P735	Retaining Ring	1
28.	700B5	Base Cover	1
29.	P736	Retaining Ring	1
30.	P734	Retaining Ring	1
31.	700B7	Power Cylinder	1
32.	P833	O-Ring, 9250-118 (No subs.)	2
33.	P739	Back-Up Ring, MS28774-14	1
34.	P294	O-Ring, 1/16 x 1/2 a 5/8	1
35.	700A8	Power Piston & Rod	1
36.	P653	O-Ring, 1/16 x 9/16 x 11/16	4
37.	700B73	Valve Sleeve	1
38.	700A67	Spring	1
39.	P829	O-Ring, 6865-012 (No subs.)	3
40.	700A15	Valve Spool	1
41.	P834	O-Ring, 6865-017 (No subs.)	2
42.	700A16	Valve Plug	1
43.	700A17	Muffler	1
44.	P279	Retaining Ring	1

TROUBLE SHOOTING

1. Check air line for correct pressure at the tool. **It must be 90 to 110 psi.**
2. Check tool for lack of hydraulic fluid (see oil filling instructions).
3. Check for oil leakage.
 - a. Oil leaking around the cap screw (5) in the head indicates that the screw is loose or the washer gasket (6) needs replacing.
 - b. If oil should leak through the by-pass hole at the base of the handle (15) the O-Rings (32) are worn or damaged.
 - c. Oil leaking from the front of the nose fitting (1) indicates that O-Rings (2) are worn or damaged.
 - d. If head is taken apart for repair check all O-Rings and carefully clean all parts before reassembling. Be sure to make any replacements with the exact O-Rings shown in the parts list to insure that the correct material and hardness is used.
4. Check valve for air leakage. If air is escaping, remove retaining ring (44) and muffler (43). Insert a 5/16-18 threaded rod or bolt into end of valve plug (42) and pull it out. Using the same procedure pull out spool (40). Replace O-Rings (39 & 41) and reassemble.

Note: It should never be necessary to remove the valve sleeve (37) unless the air supply has become so badly contaminated that the ports in the sleeve are plugged up. If this unlikelihood should occur, carefully remove spring (38) from its groove, using extreme caution not to distort the coils of the spring. Remove sleeve (37), clean thoroughly, replace O-Rings (36) and reassemble, making sure that spring (38) is seated in its groove correctly, otherwise valve will not function.

5. Check movement of piston (7). If it does not move freely or is slow in operation:
 - a. O-Rings (8) may be damaged and require replacement.
 - b. Piston (7) may be mechanically locked due to damaged parts.
 - c. Power piston may be held off its seat on rod (35) allowing oil to by-pass. Drain tool, flush thoroughly and refill with fresh oil.
 - d. Muffler (43) or air filter inside spool (40) may be plugged with dirt. Clean them thoroughly with normal solvent and back-blow with compressed air.

NOTE: We recommend the purchase of a G715KS Service Kit which contains various gaskets, O-Rings, washers and similar parts likely to need replacing in time.

WARRANTY

Seller warrants the goods conform to applicable specifications and drawings and will be manufactured and inspected according to generally accepted practices of companies manufacturing industrial or aerospace fasteners. In the event of any breach of the foregoing warranty, Buyer's sole remedy shall be to return defective goods (after receiving authorization from Seller) for replacement or refund of the purchase price, at the Seller's option. Seller agrees to any freight costs in connection with the return of any defective goods, but any costs relating to removal of the defective or nonconforming goods or installation of replacement goods shall be Buyer's responsibility. SELLER'S WARRANTY DOES NOT APPLY WHEN ANY PHYSICAL OR CHEMICAL CHANGE IN THE FORM OF THE PRODUCT IS MADE BY BUYER.

THE FOREGOING EXPRESS WARRANTY AND REMEDY ARE EXCLUSIVE AND ARE IN LIEU OF ALL OTHER WARRANTIES AND REMEDIES; ANY IMPLIED WARRANTY AS TO QUALITY, FITNESS FOR PURPOSE, OR MERCHANTABILITY IS HEREBY SPECIFICALLY DISCLAIMED AND EXCLUDED BY SELLER. THIS WARRANTY IS VOID IF SELLER IS NOT NOTIFIED IN WRITING OF ANY REJECTION OF THE GOODS WITHIN ONE (1) YEAR AFTER INITIAL USE BY BUYER OF ANY POWER RIVETER OR NINETY (90) DAYS AFTER INITIAL USE OF ANY OTHER PRODUCT.

Seller shall not be liable under any circumstances for incidental, special or consequential damages arising in whole or in part from any breach by Seller, AND SUCH INCIDENTAL, SPECIAL, OR CONSEQUENTIAL DAMAGES ARE HEREBY EXPRESSLY EXCLUDED.

For more information please contact our Technical Services Department at Tel. 714-850-6022

LOCTITE[®] is a registered trademark of Henkel Corporation
DEXRON[®] is a registered trademark of GM corporation.
PARKER[®] is a trademark of Parker Hannifin Corporation



CHERRY[®]
AEROSPACE

© 2007 CHERRY[®] AEROSPACE

Supplier's Federal Identification Code: 11815

TM-G715A
Rev.: C
DCR# 10-1064
Date: 09-29-10