

ORIGINAL INSTRUCTIONS

G704B-40SH

CherryMAX® Split Power Tool



Instruction Manual

Pass on to user to read and keep for reference

MANUAL



THE G704B-40SH TOOL

TABLE OF CONTENTS

Warranty	2
Description	3
Specifications	3
Safety Warnings	3
Fluid Safety Warnings and First Aid	4
How To Use	4
Maintenance and Repair	4
Air Valve	5
Head Cylinder	5
Power Handle	5
Priming and Bleeding Instructions	5
Troubleshooting	6
Pulling heads and extensions	6
G704B-40SH Top Assembly Parts List	7
740C29 Handle Assembly	8
704B35 Head Cylinder	9

WARRANTY

Seller warrants the goods conform to applicable specifications and drawings and will be manufactured and inspected according to generally accepted practices of companies manufacturing industrial or aerospace fasteners. In the event of any breach of the foregoing warranty, Buyer's sole remedy shall be to return defective goods (after receiving authorization from Seller) for replacement or refund of the purchase price, at the Seller's option. Seller agrees to any freight costs in connection with the return of any defective goods, but any costs relating to removal of the defective or nonconforming goods or installation of replacement goods shall be Buyer's responsibility. SELLER'S WARRANTY DOES NOT APPLY WHEN ANY PHYSICAL OR CHEMICAL CHANGE IN THE FORM OF THE PRODUCT IS MADE BY BUYER.

THE FOREGOING EXPRESS WARRANTY AND REMEDY ARE EXCLUSIVE AND ARE IN LIEU OF ALL OTHER WARRANTIES AND REMEDIES; ANY IMPLIED WARRANTY AS TO QUALITY, FITNESS FOR PURPOSE, OR MERCHANTABILITY IS HEREBY SPECIFICALLY DISCLAIMED AND EXCLUDED BY SELLER. THIS WARRANTY IS VOID IF SELLER IS NOT NOTIFIED IN WRITING OF ANY REJECTION OF THE GOODS WITHIN ONE (1) YEAR AFTER INITIAL USE BY BUYER OF ANY POWER RIVETER OR NINETY (90) DAYS AFTER INITIAL USE OF ANY OTHER PRODUCT.

Seller shall not be liable under any circumstances for incidental, special or consequential damages arising in whole or in part from any breach by Seller, AND SUCH INCIDENTAL, SPECIAL, OR CONSEQUENTIAL DAMAGES ARE HEREBY EXPRESSLY EXCLUDED.

For more information please contact our Technical Services Department at Tel. 714-850-6022

LOCTITE® is a registered trademark of Henkel Corporation
DEXRON® is a registered trademark of GM Corporation.
PARKER® is a trademark of Parker Hannifin Corporation
LUBRRIPLATE® is a trademark of Fiske Brothers Refining Co.

DESCRIPTION

G704B-40SH is a split riveter designed for the installation of blind rivets in limited access applications. The tool transmits power from the power unit through a flexible 8 foot hose to a hand held unit. By utilizing the proper pulling head, access issues and operator fatigue can be greatly reduced.

The Power supply unit, which is the Handle Assembly (740C29) is also used in G784; the Head Cylinder (704B35) is also used in G704B. Both G784 and G704B are CE certified tools.



SPECIFICATIONS

Cherry® Aerospace' policy is one of continuous development.

Specifications shown in this document may be subject to change which may be introduced after publication. For the latest information always consult Cherry® Aerospace.

AIR PRESSURE	90-110 PSI (6,2-7,6 bar)
STROKE	.518 Inch (13.16 mm)
PULLING FORCE	3,136 LbF.(13.95 kN) @ 90 PSI (6.2 bar)
CYCLE TIME	About 1 second
WEIGHT	
Pistol Grip (hand -held)	2.5 Lbs. (1,13 Kg)
Handle (Flood Unit)	5.3 Lbs. (2,4 Kg)
NOISE LEVEL	< 85dB(A)
AIR CONSUMPTION	0.34 SCF/cycle (9.6L/cycle)

SAFETY WARNINGS

- Do not use beyond the design intent; do not use substitute components for repair.
- Operating this tool with a damaged or missing stem deflector, or using the deflector as a handle, may result in severe personal injury. Rotate the pin deflector facing away from the operator.
- Wear proper PPE when operating, repairing or overhauling this tool (  ).
- Any modification will void warranty and shall be at the customer's entire responsibility.
- Maintain the tool in a safe working condition at all times and examined at regular intervals for damage.
- Before disassembling the tool for repair, refer to the maintenance instructions. All repairs shall be undertaken only by personnel trained in Cherry installation tools.
- Disconnect the air line from the tool inlet before servicing, adjusting, fitting or removing any accessory.
- Ensure that the vent holes do not become blocked or clogged and the hoses are in good condition.
- Wash thoroughly after handling the fluid; excessive contact could cause rashes.
- Operating air pressure not to exceed 110 psi (7.6 bar); use of a pre-set regulator (P1505) is recommended.
- Do not operate the tool without the pulling head in place.
- All retaining rings, screwed end caps, air fittings, trigger valves and pulling heads should be attached securely and examined at the end of each working shift.
- Do not pull rivet in the air or directed at any person.
- **Do not pound on the rear of the tool head to force rivets into holes as this will damage the tool.**

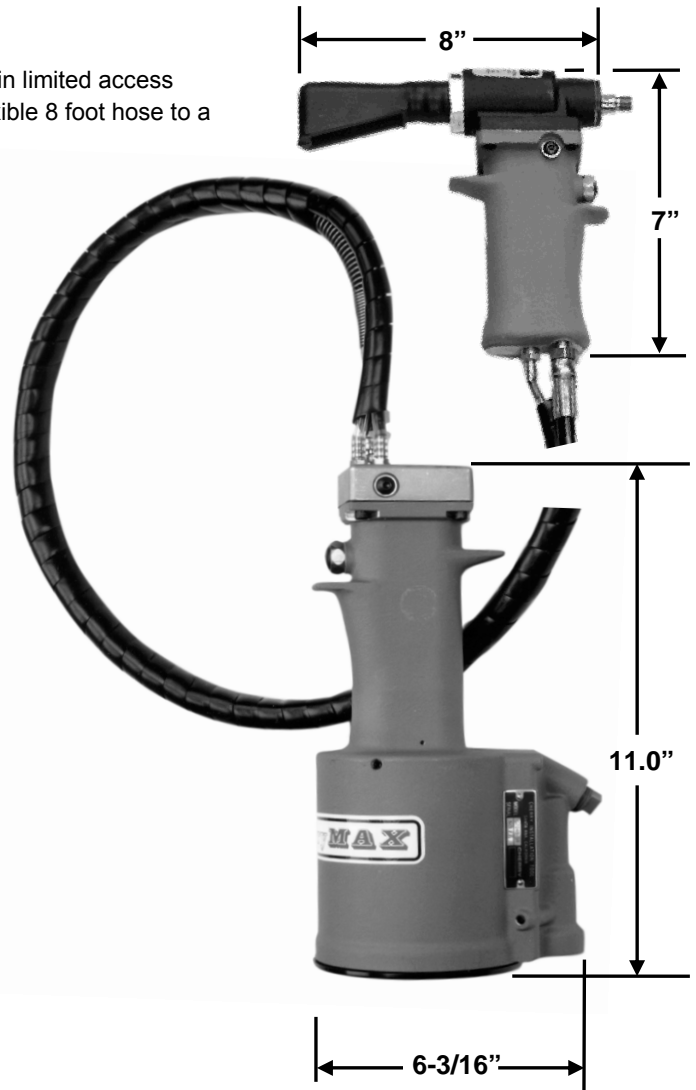

- Safety warnings must be explained all operators as part of training.

FLUID SAFETY AND FIRST AID INFORMATION (ATF type "A")

- **SKIN EXPOSURE:** Wash thoroughly with soap and water as soon as possible. Casual contact requires no immediate attention. If irritation develops, consult a physician.
- **INGESTION:** Seek medical attention immediately. **DO NOT INDUCE VOMITING.**
- **INHALATION:** No significant adverse health effects are expected to occur on short term exposure. Remove from contaminated area. Apply artificial respiration if needed. If unconscious, consult physician.
- **EYES:** Flush with copious amounts of water. If irritation develops, consult a physician.
- **FIRE:** Suitable extinguishing media: CO2, dry powder, foam or water fog. **DO NOT** use water jets.
- **ENVIRONMENT:** Waste Disposal: In accordance with local, state and federal regulations.
- **SPILLAGE:** Prevent entry into drains, sewers and water courses. Soak up with diatomaceous earth or other inert material. Store the spent fluid in appropriate containers for disposal.
- **HANDLING:** Eye protection required. Protective gloves recommended. Chemically resistant boots and apron recommended. Use in well-ventilated area.
- **COMBUSTIBILITY:** It is slightly combustible when heated above flash point. It will release flammable vapors which can burn in open or be explosive in confined spaces if exposed to source of ignition.
- **STORAGE:** Avoid storage near open flame or other sources of ignition.



HOW TO USE THE G704B-40SH

After attaching the proper pulling head, connect to a regulated airline (if the tool is equipped with the preset regulator P-1505, air source may be unregulated). The riveter has 8 foot extension hoses, allowing it to reach into tight spaces and reduce operator strain. The Handle Assembly may be placed on the floor.



MAINTENANCE AND REPAIR

This riveter has been manufactured to give maximum service with minimum care. For optimum function:

1. The hydraulic system is to be full of oil and free from air at all times.
2. Use clean and dry air to prevent premature wear and clogging of the air components.
3. Inspect the riveter for fluid leaks routinely.

TOOL OVERHAUL / REPAIR

Tool overhaul is needed in case of tool malfunction, massive fluid loss or as part of your routine maintenance program.

Tips for properly servicing the tools:

- **Before proceeding with any repair, make sure that the riveter is disconnected from the air supply and any attachments are removed (pulling head, stem deflector).**
- **Use a blunt bent hook tool to remove the O-rings from their groove; use care not to scratch the seal surfaces.**
- **Inspect all components for signs of wear or breakage; replace any damaged components.**
- **Replace all gaskets, O-rings and back-up rings; lubricate O-rings with proper lubricant before re-assembling.**

- TOOLS NEEDED:
- **G740KT** – tool kit, **Needle Nose Pliers**,
 - **G704B-40SR/40SHKS** – service kit:

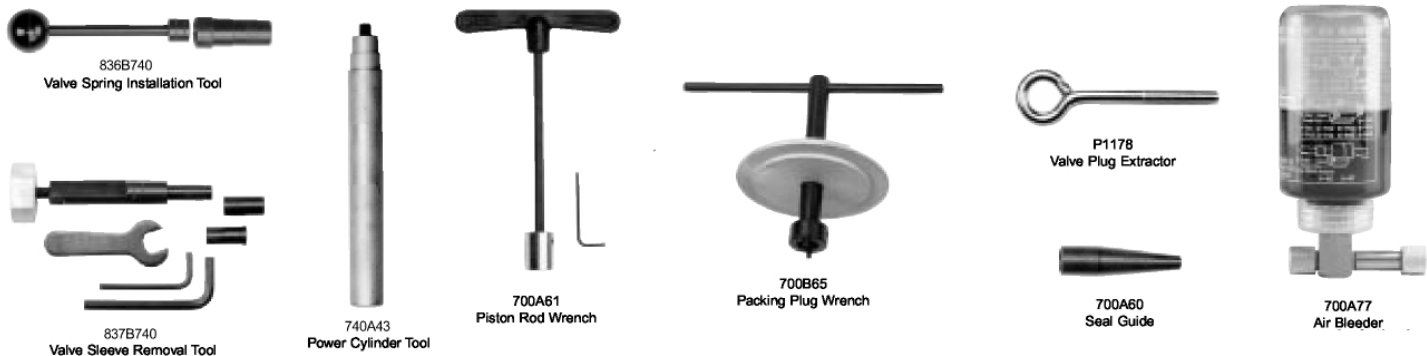

THE G740KT TOOL KIT

Also included: 701A61 Seal Guide, 740A43 Power Cylinder Tool, 740A42 Seal Guide, 744-103 Seal Guide, 744-104 Seal Guide.

AIR VALVE (See Handle Cross Section on page 8 for details).

- Remove retaining ring (29) and muffler (28). Insert the valve plug extractor (P1178) into end of valve plug (27) and pull it out. Using the same procedures, pull out valve spool sub-assembly (26).
- Use needle nose pliers to grasp the end of the spring (24), turn clockwise and pull out to dislodge from groove in handle.
- With spring removed, valve sleeve (23) can be pulled out if necessary; use the valve sleeve removal tool (837B740).
- Use the valve spring installation tool (836B740) to snap the spring (24) into its groove when re-assembling.

HEAD CYLINDER SUB-ASSEMBLY (Head Sub-Assembly on page 9 for details).

- In order to service the Head Cylinder, remove the four socket head cap screws (5) and remove it from the handle (6); empty the fluid into a container; dispose of the oil according to environmental regulations.

HANDLE SUB-ASSEMBLY (See Handle Cross Section on page 8 for details).

- Remove the Base Cover (15 through 18); engage the piston rod wrench (700A61) onto the top the head of the power piston rod (4.) and push it to the bottom. Remove the locknut (13) with the help of a 7/16" socket wrench.
- While holding the piston rod wrench, unthread the air piston (12) using the packing plug wrench (700B65).
- Slide the power piston (4) back up to the end of its travel. Remove the packing plug (8) with the help of wrench 700B65.
- The Power cylinder (5) can be tapped out through the bottom with the help of the power cylinder tool (700A43) and a mallet.
- When re-assembling, tighten the locknut (13) onto the power piston rod (4) to about 50-59 in-Lb. (5.65-6.67 Nm)

PRIMING AND BLEEDING INSTRUCTIONS

Use automatic transmission fluid (ATF) type "A" (no substitutes). Dexron® III ATF is recommended.



FLUID PROPERTIES

<i>Specific gravity</i>	0.863
<i>Weight per gallon</i>	7.18 lbs.
<i>Open flash point</i>	>200°C (392°F)

Priming Instruction:

- After servicing, the riveter needs to be primed with fluid. In order to accomplish that, with the Handle Manifold off fill the Handle Assembly with fluid to the top. After reattaching the Manifold, follow the Bleeding instructions below.

Bleeding Instructions (air removal and fluid refill)

What is needed: a 1/8" Allen Wrench; the 700A77 Bleed Bottle

Procedure:

- Connect the Riveter to an air source.
- Remove screw from the side of the Cylinder Head and thread-in the bleed bottle bottom up (see picture).
- Cycle until no more bubbles surface inside of bottle.
- When completed, remove the Bleed Bottle and re-attach the side screw with the seal. Make sure it is properly tightened to prevent any leaks.

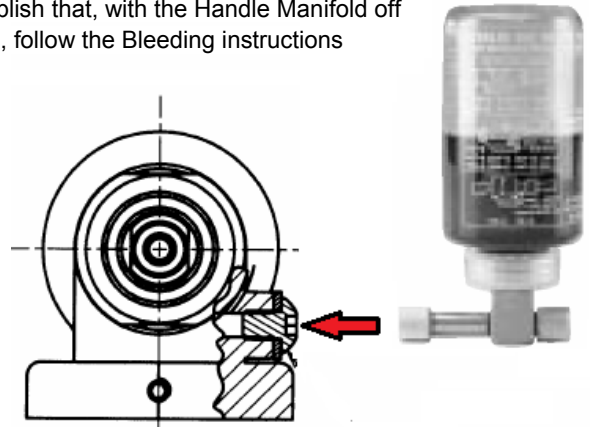

TROUBLESHOOTING

PROBLEM	POSSIBLE REASONS / SOLUTIONS
Piston does not move after depressing Trigger	- No air supply is connected: Connect to a clean, filtered air source at 90 to 110 psi (6,2 to 7,6 bar).
	- Faulty trigger: Remove and replace trigger assembly.
	- Broken power piston: Service the Handle Subassembly.
Short stroke or low pull force	- Significant fluid loss: Bleed the system to purge the air out. If performance doesn't improve, or excessive leakage continues, see below.
Head Cylinder Fluid leakage	- Leaks around the seals or fittings indicate that they are not tightened to seal properly: Tighten until no more leaks are observed.
	- Leaks at the front of head cylinder indicate worn/ damaged seals.
	Service head cylinder per instructions provided herein.
Air leakage at the spool valve	- Broken or dislodged valve spring: Service and replace.
	- Worn or damaged valve spool seals: Disassemble and service air valve per Air Sub-Assembly Overhaul Instructions.
Head piston is slow or seizes	- Piston or seal damage: Service head cylinder.
	- Clogged air muffler or filter: Clean thoroughly with solvent and back-blow with compressed air.

PULLING HEADS AND EXTENSIONS

A. PULLING HEADS

Pulling Heads are not furnished with riveter and must be ordered separately; see Tool Sheet for details on service and about all the fastener capabilities of each pulling head.

Pulling Head	Type	Adapter	Rivet	Rivet Diameters	Maximum Grip ¹
H701B-456 H747-456	Straight	-	CherryMAX Bulb	1/8, 5/32, 3/16 ^{2,3}	All
			CherryMAX "AB"	1/8, 5/32, 3/16 ³	-4 ¹
			MBC L/C	1/8, 5/32, 3/16	-4 ¹
H753A-456	Right Angle	-	CherryMAX Bulb	1/8, 5/32, 3/16 ^{2,3}	All
			CherryMAX "AB"	1/8, 5/32, 3/16 ³	-4 ¹
H781-456	Offset	-	CherryMAX Bulb	1/8, 5/32, 3/16 ^{2,3}	All
			CherryMAX "AB"	1/8, 5/32, 3/16 ³	-4 ¹
H9015-Series	Straight	704A9	MS ⁴	3/32, 1/8, 5/32, 3/16	All
H955-Series	Straight	-	CherryLock "A"	3/32, 1/8, 5/32, 3/16 ³	-4 ¹
H782	Straight	-	CherryMAX Bulb	1/8, 5/32, 3/16 ^{2,3}	All
			CherryMAX "AB"	1/8, 5/32, 3/16 ³	-4 ¹
			MBC L/C	1/8, 5/32, 3/16	-4 ¹

1. On the first stroke. 2. Nominal and oversize. 3. No 3/16 aluminum, alloy steel and monel only. 4. Serrated stems only.

B. EXTENSIONS

Extensions are offered in order to extend the reach of the pulling head even deeper into narrow access areas.

Extension Number	Length (In)	National Stock No.
704A12-2	2.0	5130-01-145-0206
704A12-4	4.0	5130-01-145-0207
704A12-6	6.0	5130-01-145-0208
704A12-12	12.0	5130-01-178-0331

G704B-40SH TOP LEVEL COMPONENT LIST

22	1	WARNING LABEL	435A60
21	2	HOSE FITTING	P-1198
20	1	CA-PLUG	P-273
19	1	NAME PLATE	435A2
18	2	DRIVE SCREW	P-134
17	4	HEX SOC. CAP SCREW	P-91
16	1	HANDLE MANIFOLD	744C46
15	1	SWIVEL ADAPTER	P-533
14	1	HOSE ASSEMBLY	P-1182
13	1	CHERRYMAX LABEL	435B32-1
12	1	HANDLE ASSEMBLY	740C29
11	2	BUTTON HD. SOC. SCREW	P-573
10	2	STAT-O-SEAL	P-572
9	2	HOSE FITTING	P-1181
8	2	TUBING-FLEXIBLE	704A48-8
7	1	CABLE WRAP	704A47-8
6	1	HANDLE	704C28
5	4	HEX SOC. CAP SCREW	P-27
4	1	TRIGGER ASSEMBLY	703A33
3	2	O-RING	P-832
2	2	HEAD GASKET	700A22
1	1	HEAD ASSEMBLY	704B35
ITEM NO.	REQ.	DESCRIPTION	DWG. NO.

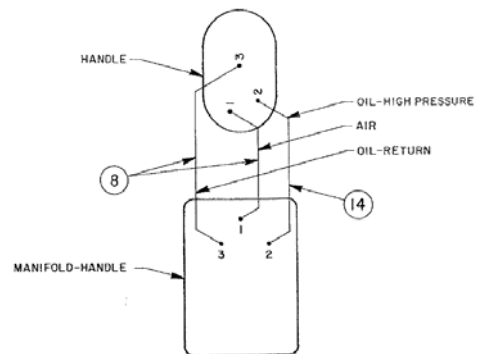
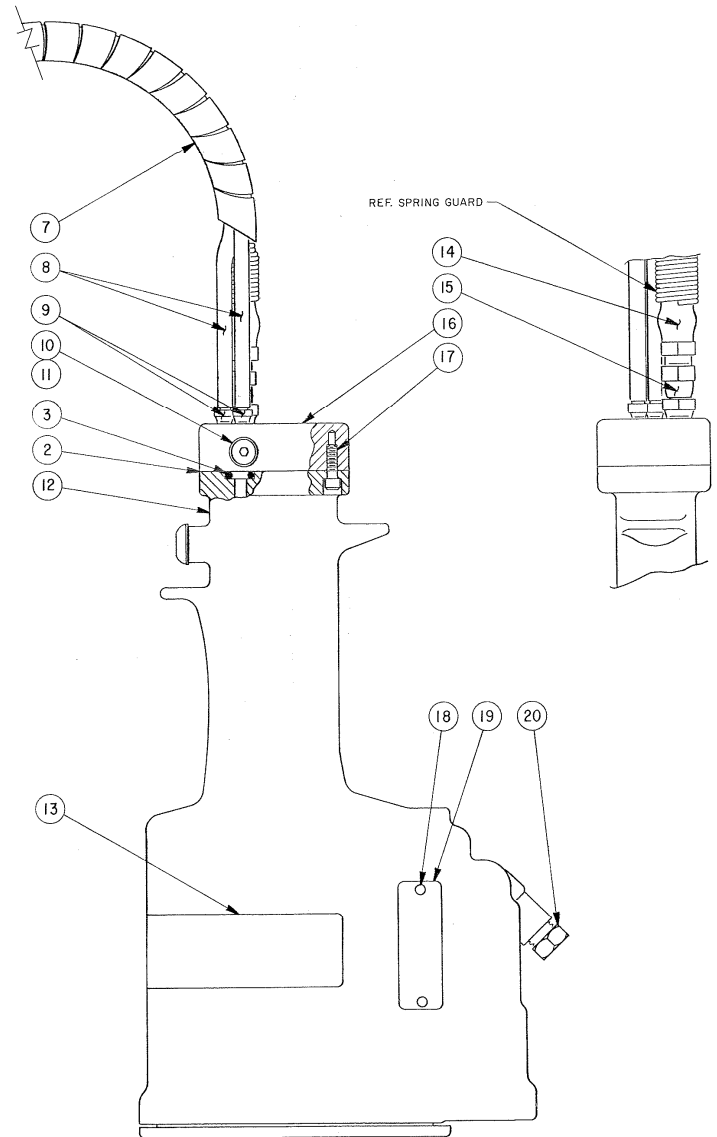
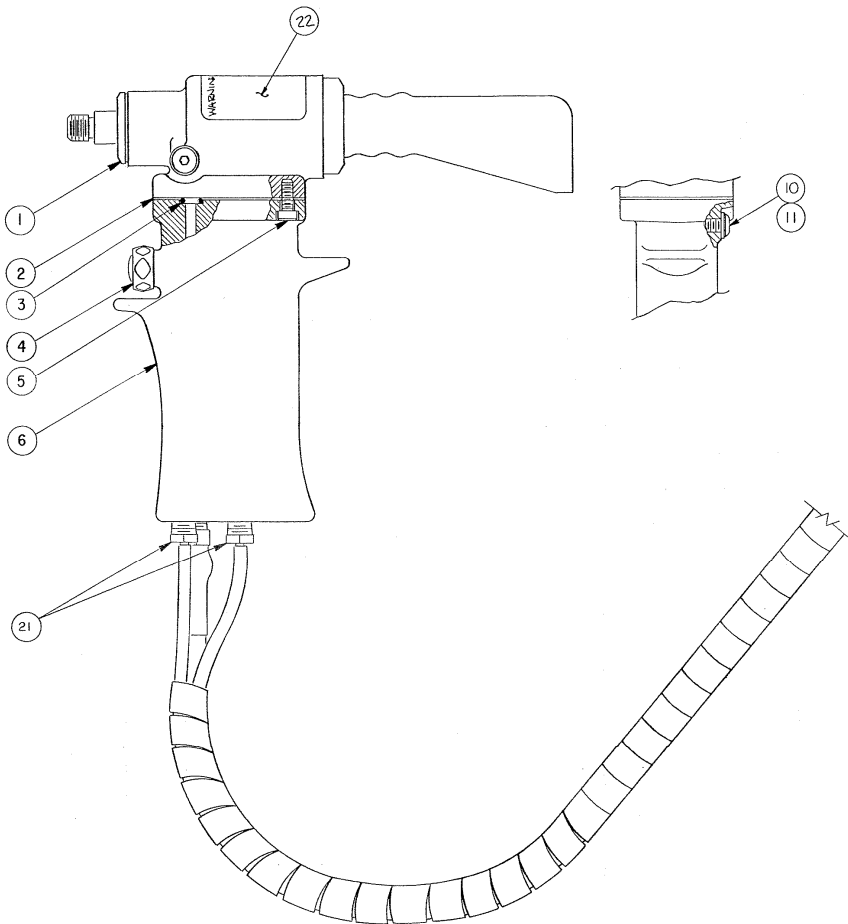

HOSE ATTACHMENT DIAGRAM

740C29 HANDLE ASSEMBLY

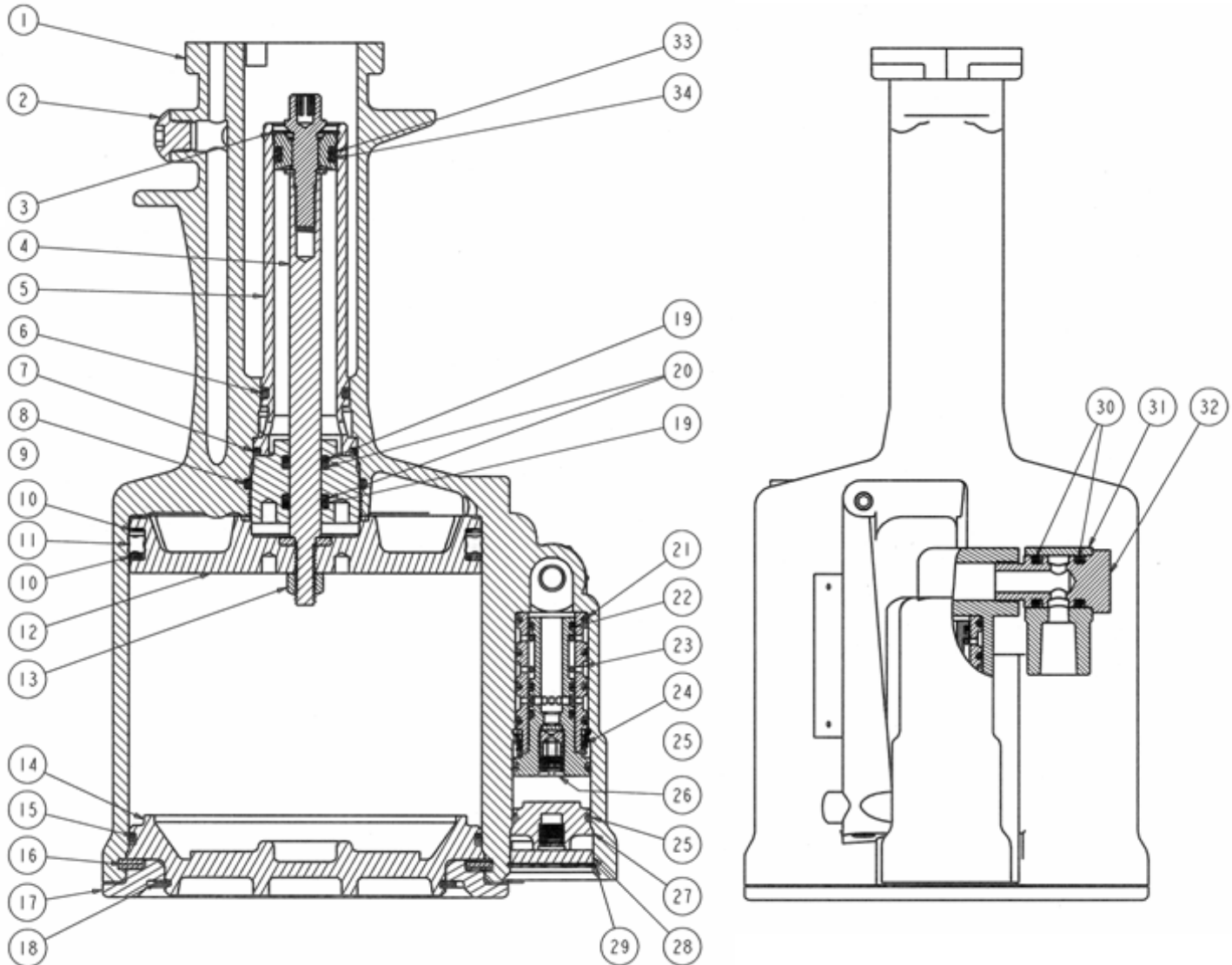

17	1	740B5	COVER, BASE
16	1	P-886	RING, RETAINING (INT. Ø4.250)
15	1	P-890	O-RING(4.193,3.897,.103)
14	1	740C4	BASE, HANDLE
13	1	P-737	NUT, CONELOK(1/4-20, GRADE C)
12	1	740B6	PISTON, AIR
11	1	P-887	RING, QUAD(4.270,3.850,.210)
10	2	P-909	RING, BACK-UP(4.245,3.875,.034)
9	1	740B13	PLUG, PACKING
8	1	P-889	O-RING(1.505,1.299,.103)
7	1	P-892	O-RING(1.255,1.049,.103)
6	1	P-833	O-RING(1.068,.862,.103)
5	1	740C7	CYLINDER, POWER
4	1	740A8	SUB-ASSY., POWER PISTON & ROD
3	1	P-885	RING, RETAINING (INT. Ø.781)
2	1	530A113	SCREW, BUTTON HD, CAP 10-24x5/8
1	1	743A11	HANDLE
ITEM NO.	REQ.	PART NO.	DESCRIPTION

34	1	P-508	O-RING(.755,.549,.103)
33	1	P-908	RING, BACK-UP(.738,.562,.088)
32	1	530A35	BOLT, SWIVEL
31	1	530A34	SWIVEL
30	2	P-195	O-RING (.630,.424,.103)
29	1	P-321	RING, RETAINING (INT. Ø1.000)
28	1	740A17	MUFFLER
27	1	740B16	PLUG, VALVE
26	1	740A15	SPOOL, VALVE
25	2	P-848	O-RING(.941,.801,.070)
24	1	740A18	SPRING
23	1	740B14	SLEEVE, VALVE
22	3	P-891	O-RING(.566,.426,.070)
21	4	P-268	O-RING(.816,.676,.070)
20	2	P-115	RING, BACK-UP (.551,.375,.088)
19	2	P-838	O-RING(.568,.362,.103)
18	1	P-884	RING, RETAINING (EXT. Ø3.375)



704B35 HEAD SUB-ASSEMBLY

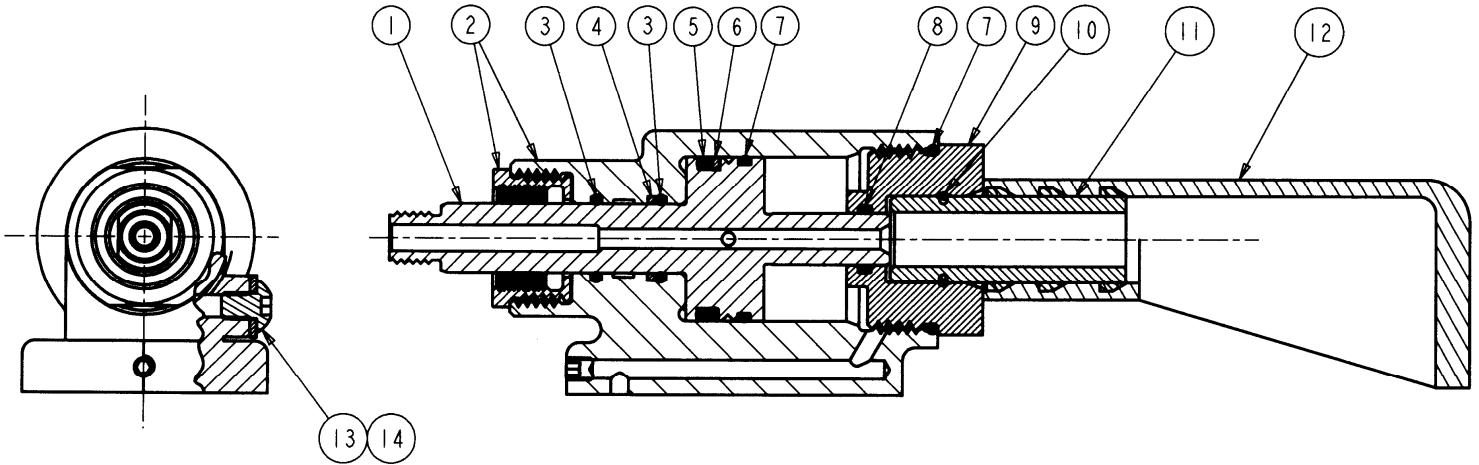

14	1	P-572	STAT-O-SEAL (.430, .180, .125)
13	1	P-573	SCREW, BUT. SOC. HD, 10-32 X 1/4
12	1	530A16	DEFLECTOR, PIN
11	1	703A13	FITTING, DEFLECTOR
10	1	P-880	RING, RETAINING (NONSTANDARD)
9	1	704B4	CAP, HEAD CYLINDER
8	1	P-112	O-RING (.504, .364, .070)
7	2	P-870	O-RING (1.191, 1.051, .070)
6	1	P-1000	BACK-UP RING (1.176, 1.000, .088)
5	1	P-931	O-RING (1.193, .987, .103)
4	1	P-998	BACK-UP RING (.609, .503, .053)
3	2	P-701	O-RING (.629, .489, .070)
2	1	704C19	CYLINDER, HEAD
1	1	704C3	PISTON, HEAD
ITEM NO.	REQ.	PART NO.	DESCRIPTION