

Original Instructions

G702A

Lightweight Nut-Plate Power Tool



Instruction Manual CE

Pass on to user to read and keep for reference



MANUAL



CHERRY[®]
AEROSPACE

1224 East Warner Ave,
Santa Ana, CA 92705
Tel: 1-714-545-5511
Fax: 1-714-850-6093
www.cherryaerospace.com

THE G702A TOOL

TABLE OF CONTENTS

Description 2

Specifications for G702A 2

Safety Warnings 2

Putting the tool in service 3

How to Use the G702A 3

Maintenance and Repair 4

 Dexron® III ATF Safety Instructions 4

Fill and Bleed Instructions 5

Trouble-Shooting Guide 5

Overhaul Guide 6

 Air Valve 6

 Head Sub-Assembly 6

 Handle Sub-Assembly 7

Nose Piece selection 7

Cross Section Drawing Of G702A 8

Parts List For G702A Riveter 9

Exploded View of G702A 10

Declaration of Conformity 11

WARRANTY

Seller warrants the goods conform to applicable specifications and drawings and will be manufactured and inspected according to generally accepted practices of companies manufacturing industrial or aerospace fasteners. In the event of any breach of the foregoing warranty, Buyer's sole remedy shall be to return defective goods (after receiving authorization from Seller) for replacement or refund of the purchase price, at the Seller's option. Seller agrees to any freight costs in connection with the return of any defective goods, but any costs relating to removal of the defective or nonconforming goods or installation of replacement goods shall be Buyer's responsibility. SELLER'S WARRANTY DOES NOT APPLY WHEN ANY PHYSICAL OR CHEMICAL CHANGE IN THE FORM OF THE PRODUCT IS MADE BY BUYER.

THE FOREGOING EXPRESS WARRANTY AND REMEDY ARE EXCLUSIVE AND ARE IN LIEU OF ALL OTHER WARRANTIES AND REMEDIES; ANY IMPLIED WARRANTY AS TO QUALITY, FITNESS FOR PURPOSE, OR MERCHANTABILITY IS HEREBY SPECIFICALLY DISCLAIMED AND EXCLUDED BY SELLER. THIS WARRANTY IS VOID IF SELLER IS NOT NOTIFIED IN WRITING OF ANY REJECTION OF THE GOODS WITHIN ONE (1) YEAR AFTER INITIAL USE BY BUYER OF ANY POWER RIVETER OR NINETY (90) DAYS AFTER INITIAL USE OF ANY OTHER PRODUCT.

Seller shall not be liable under any circumstances for incidental, special or consequential damages arising in whole or in part from any breach by Seller, AND SUCH INCIDENTAL, SPECIAL, OR CONSEQUENTIAL DAMAGES ARE HEREBY EXPRESSLY EXCLUDED.

For more information please contact our Technical Services Department at Tel. 714-850-6022

LOCTITE® is a registered trademark of Henkel Corporation
DEXRON® is a registered trademark of GM corporation.
PARKER® is a trademark of Parker Hannifin Corporation
LUBRRIPLATE® is a trademark of Fiske Brothers Refining Co.

DESCRIPTION

The Cherry G702A is a pneumatic-hydraulic tool designed specifically for the most efficient installation of Nut-plate rivets. Its durable, all metal housing makes this extremely robust tool ideal for use in rugged shop environments. It has many ergonomic features: very light weight, comfortable fit in the operator's hand and it can be operated in any position with one hand. The H702-3NPR pulling head fits directly on the G702A tool to install -3, -4, 2.5mm and 3mm Nut-plate rivets. See the section on pulling heads for installation instructions and nosepiece selection.

SPECIFICATIONS FOR G702A

CHERRY's policy is one of continuous development. Specifications shown in this document may be subject to change which may be introduced after publication. For the latest information always consult the Cherry Aerospace Website or contact us.

AIR PRESSURE	90 to 110 psi (6.2 bar to 7.6 bar)
STROKE	0.75 inch (19 mm)
PULLING FORCE	1100 Pounds (4.9 kN) @ 90 PSI (6.2 bar)
CYCLE TIME	Approximately One Second
WEIGHT	3.5 Pounds (1.59 kg)
NOISE LEVEL	65 dB (A)
VIBRATION	less than 2.5 m/s ²
AIR CONSUMPTION	0.066 SCF/cycle (1.87 L/cycle)

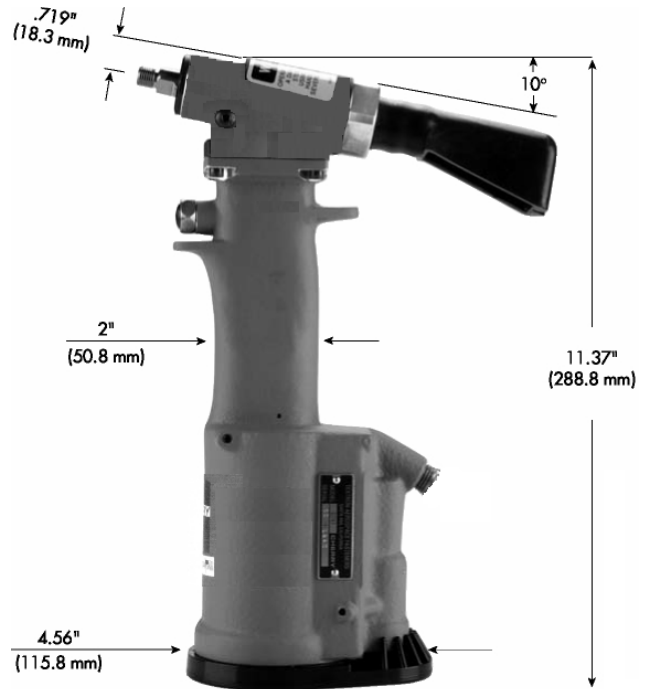

SAFETY WARNINGS

- Do not use beyond the design intent; do not use substitute components for repair.
- Operating this tool with a damaged or missing stem deflector, or using the deflector as a handle, may result in severe personal injury. Rotate the pin deflector facing away from the operator
-  Wear proper PPE when operating, repairing, or overhauling this tool.
- Any modification will void warranty and shall be at the customer's entire responsibility.
- Maintain the tool in a safe working condition at all times and examined at regular intervals for damage.
- Before disassembling the tool for repair, refer to the maintenance instructions. All repairs shall be undertaken only by personnel trained in Cherry installation tools.
- Disconnect the air line from the tool inlet before servicing, adjusting, fitting or removing any accessory.
- Ensure that the vent holes do not become blocked or clogged and the hoses are in good condition.
- Wash thoroughly after handling the fluid; excessive contact could cause rashes.
- Operating air pressure not to exceed 110 psi (7.6 bar); use of a pre-set regulator (P1505) is recommended
- Do not operate the tool without the pulling head in place.
- All retaining rings, screwed end caps, air fittings, trigger valves and pulling heads should be attached securely and examined at the end of each working shift.
- Do not pull rivet in the air or directed at any person.
- Do not pound on the rear of the tool head to force rivets into holes as this will damage the tool.
- Safety warnings must be explained all operators as part of training.

PUTTING THE TOOL IN SERVICE

Tool without integral Air Pressure Regulator (P-1505)



Tool with Integral Air Pressure Regulator (P1505)



HOW TO USE THE G702A

After selecting the proper pulling head and attaching it securely to the G702A, connect the air line to the tool. Insert the rivet stem into the pulling head until the head of the rivet is in contact with the pulling head sleeve. This will ensure full engagement between the jaws and the rivet stem and will prevent slippage.

Once the rivet stem is inserted in the H702-3NPR pulling head, the rivet must be installed. Insert the rivet into the application and pull the trigger to activate the tool. Upon the release of the trigger, the stem will eject to the rear of the tool.

If unclear, contact a CHERRY® representative.



MAINTENANCE AND REPAIR

The G702A has been manufactured to give maximum service with minimum care. In order that this may be accomplished, the following recommendations should be followed:

1. The hydraulic system should be full of oil and free from air at all times.
2. Keep excessive moisture and dirt out of air supply to prevent wear of air valve, air cylinder and air piston.
3. Tool should be routinely inspected for oil leaks.

Use automatic transmission fluid Type "A" (no substitutes). CHERRY® recommends using ATF, Dexron® III.

FIRST AID

Skin: Wash thoroughly with soap and water as soon as possible. Casual contact requires no immediate attention. If irritation develops, consult a physician.

Ingestion: Seek medical attention immediately. **DO NOT INDUCE VOMITING.**

Eyes: Flush with copious amounts of water. If irritation develops, consult a physician.

Inhalation: No significant adverse health effects are expected to occur on short term exposure. Remove from contaminated area. Apply artificial respiration if needed. If unconscious, consult physician.

FIRE

Suitable extinguishing media: CO2, dry powder, foam or water fog. **DO NOT** use water jets.

ENVIRONMENT

Waste Disposal: In accordance with local, state and federal regulations.

Spillage: Prevent entry into drains, sewers and water courses. Soak up with diatomaceous earth or other inert material.

Store the spent fluid in appropriate containers for disposal.

HANDLING

Eye protection required. Protective gloves recommended. Chemically resistant boots and apron recommended. Use in well-ventilated area.

COMBUSTIBILITY

It is slightly combustible when heated above flash point. It will release flammable vapors which can burn in open or be explosive in confined spaces if exposed to source of ignition.

STORAGE

Avoid storage near open flame or other sources of ignition.

PROPERTIES

<i>Specific gravity</i>	0.863
<i>Weight per gallon</i>	7.18 lbs.
<i>Open flash point</i>	>200°C (392°F)



FILL AND BLEED INSTRUCTIONS

To replace a small amount of oil in the tool, remove cap screw (15), attach the Cherry air bleeder (700A77), connect the tool to the air line and cycle several times. This will ensure the removal of any air from the hydraulic system and its replacement with fluid. Should it become necessary to completely refill the tool (such as would be required after the tool has been dismantled and re-assembled), take the following steps:

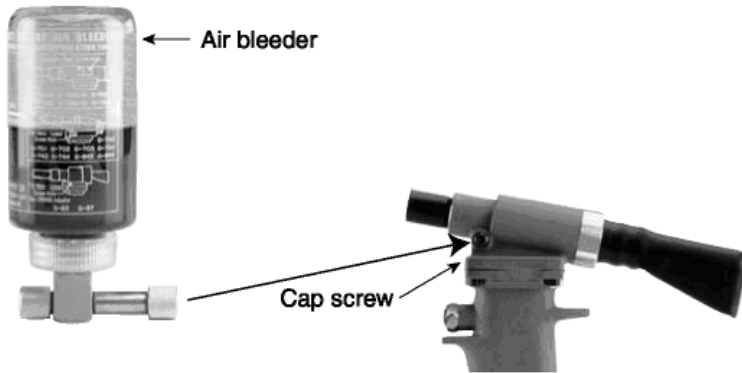

1. Remove head assembly (1) from handle (32) by unscrewing cap screws (50).
2. Fill handle assembly (32) with the recommended fluid to within 1/8" (3.175mm) of the top of the handle casting.
3. Place head assembly (1) on handle (32), being sure gasket (49), and O-ring (48), are properly in place. Tighten cap screws (50) uniformly to prevent leakage around gasket.
4. Remove cap screw (15) and attach the Cherry air bleeder (700A77). Connect the tool to the air line and cycle a number of times. This will ensure the removal of any air from its hydraulic system and its replacement with fluid.

TROUBLESHOOTING GUIDE

PROBLEM	POSSIBLE REASONS / SOLUTIONS
Piston does not move after depressing Trigger	- No air supply is connected: Connect to a clean, filtered air source at 90 to 110 psi (6,2 to 7,6 bar).
	- Faulty trigger: Remove and replace trigger assembly.
	- Broken power piston: Service the Handle Subassembly.
Short stroke or low pull force	- Significant fluid loss: Bleed the system to purge the air out. If performance doesn't improve, or excessive leakage continues, see below.
Head Cylinder Fluid leakage	- Leaks around the seals or fittings indicate that they are not tightened to seal properly: Tighten until no more leaks are observed.
	- Leaks at the front or back of head cylinder indicate worn/ damaged seals
	Service head cylinder per instructions provided herein
Air leakage at the spool valve	- Broken or dislodged valve spring.
	- Worn or damaged valve spool seals: Disassemble and service air valve per Air Sub-Assembly Overhaul Instructions.
Head piston is slow or seizes	- Piston or seal damage: Service head cylinder.
	- Oil bypassing due to power piston displacement off its seat: Service Handle Subassembly per instructions provided below.
	- Clogged air muffler or filter Clean thoroughly with solvent and back-blow with compressed air.



G701/G704KT TOOL KIT

OVERHAUL

The disassembly and re-assembly procedures can be accomplished by following the instructions below and the drawings on pages 8 & 10. **Use extreme care during disassembly and re-assembly not to mar, nick or burr any smooth surface that comes in contact with O-rings.** Before installing O-rings, be sure to apply an O-ring lubricant. It is recommended that special assembly tools, which can be ordered under part number **G701/G704KT**, be used to overhaul this tool. Service kit, **G702AKS**, which contains a complete set of O-rings, back-up rings, screws, washers and gaskets should be ordered.

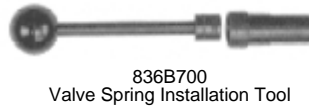

836B700
Valve Spring Installation Tool



8375700
Valve Sleeve Removal Tool



700A62
Power Cylinder Tool



700A61
Piston Rod Wrench

Not shown, but included: 701A67 Seal Guide, 702862 Power Cylinder Tool, 703A53 Seal Guide, 702A64 Seal Guide.



700B65
Packing Plug Wrench

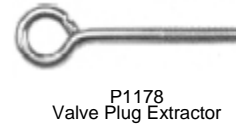

P1178
Valve Plug Extractor



700A460
Seal Guide



700477
Air Bleeder

AIR VALVE

- Remove retaining ring (47) and muffler (46). Insert a valve plug extractor (P1178) into end of valve plug (45) and pull it out. Using the same procedures, pull out valve spool sub-assembly (40).
- Use needle nose pliers to grasp the end of the spring (39), turn clockwise and pull out to dislodge from groove in handle.
- With spring removed, valve sleeve (38) can be pulled out using the valve sleeve removal tool (837B700).

To re-assemble, reverse the above procedures, being certain that all O-rings are properly lubricated. To avoid damaging the O-rings (2), carefully install sleeve (38) with your finger. Gently push and wiggle sleeve to allow O-rings to slip past inner ports. Spring (39) is best installed using a valve spring installation tool (836B700) to push the large diameter coil into the groove. This requires care as the tool will not operate if the spring is not anchored firmly.

HEAD SUB-ASSEMBLY

- Disconnect the air supply and remove the complete pulling head from the tool before attempting to disassemble the head assembly.
- Remove the four socket head cap screws (50). Lift head assembly from the handle (32). Remove O-ring (48) and gasket (49). Empty the oil into a container by pouring from the handle. Dispose of the oil according to environmental regulations.
- Remove end cap (10). Push against threaded end of head piston (4) and slide it out of head cylinder (1). Be careful not to damage threads or cause burrs on polished head piston rod surface.
- O-rings (2) and back-up ring (3) can now be removed using a bent hook. O-ring (8) can be removed in the same manner.
- Upon re-assembly, be sure to install O-rings and back-up rings carefully to avoid cutting them. Always lubricate all O-rings. Just prior to placing the head sub-assembly onto the handle, see Fill and Bleed Instructions. Also make sure to place O-ring (48) on top of the handle in its groove, and then the gasket (49) over the O-ring (48).
- Tighten the four socket head cap screws (50) uniformly to prevent leakage around the gasket.
- Purge system of air using Cherry air bleeder (700A77) according to Fill & Bleed Instructions.

HANDLE SUB-ASSEMBLY

- Disconnect tool from air supply and remove parts (25) through (29).
- Remove the head sub-assembly using the instructions in the head sub-assembly section.
- Place piston rod wrench (700A61) down into the top of the handle (32), into the hex socket in the head of the power piston rod (37). While holding this wrench, remove the locknut (24) using the 7/16" socket in packing plug wrench (700865).
- Still holding the piston rod wrench, remove the air piston (22) using the packing plug wrench (700B65) by turning counterclockwise. When air piston (22) is completely freed from the piston rod, tap or push on the piston rod wrench to eject the piston from bottom of handle.
- Slide power piston rod (37) back up to the end of its travel. Using the packing plug wrench (700B65), remove packing plug (19). It may be necessary to hold the handle upside down in a vise while removing the packing plug.
- Power cylinder (33) can be tapped out by lowering power cylinder tool (700A62) down into the top of the handle on to top of cylinder. The O-rings (16) and backup rings (17) are best removed and replaced by using a thin bent hook.

To re-assemble the handle, reverse the above procedure, being certain that all the O-rings are properly lubricated before installation. Attach the seal guide (700A60) to the piston rod (37) and with a mallet, tap the piston rod through the packing plug (19). When re-assembling a replacement air piston, items (20) through (23), follow the instructions given below:

- Clamp piston rod wrench (700A61) in a vise with the hex shaft pointed up.
- Turn the handle upside down and place the hex end of the power piston rod (37) onto the wrench. Push handle casting down until it stops.
- Assemble O-ring (20) to air piston (22).
- Place large washer (21) over the threaded end of the power piston rod (37).
- Place the air piston (22) into handle bore.
CAUTION: Be sure that the radial pattern embossed on the side of air piston is facing downward towards the large washer (21) and the smooth side of the air piston is facing you.
- Place the small washer (23) over the threaded end of the power piston rod (37). Thread the locknut (24) onto the power piston rod (37) and tighten between 50 in.-lb (5.65 N-m) and 59 in.-lb (6.67 N-m).

NOSEPIECE SELECTION

H702-3NPR PULLING HEAD -

The G702A requires only one pulling head to install four diameters of nut-plate rivets.

Rivet Diameter	Nosepiece ²	Maximum Grip ¹
-3	728A9-3	-12
2.5mm	728A9-3	-12
-4	728A9-104	-12
3mm	728A9-104	-12

1. On the first stroke.
2. Both nosepieces included with pulling head.

See the Tool Sheet for a bill of materials and assembly instructions.

CROSS SECTION OF G-702A

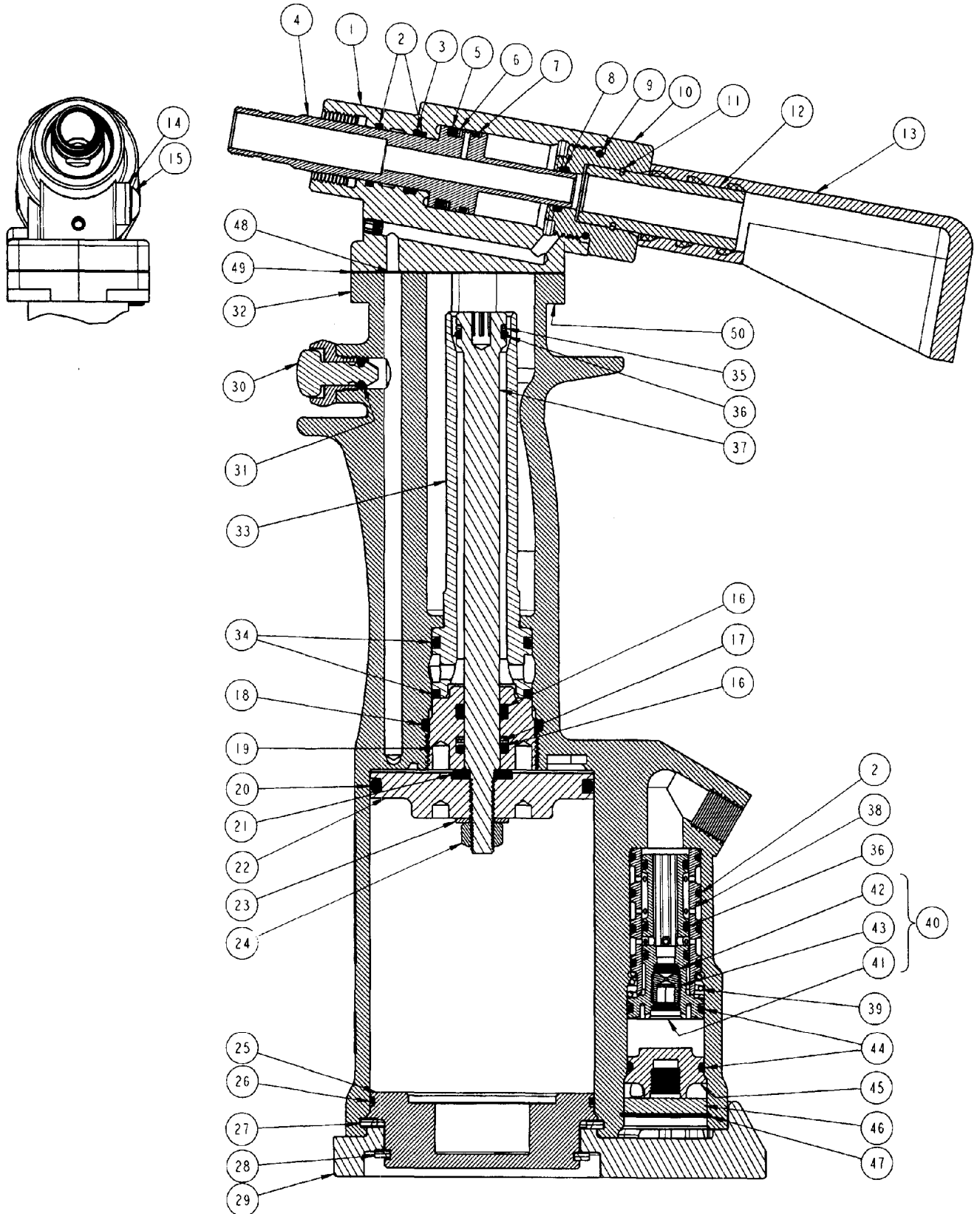

PART LIST FOR G702A

ITEM	PART No	DESCRIPTION	QTY	
702-054 (G702A RIVER ASSEMBLY)				
702B15 SUB-ASSEMBLY, HEAD				
1	702C2	SUB -ASSEMBLY, HEAD CYLINDER	1	
2	P-653	O-RING (.691, .551, .070)	6	
3	P-883	RING, BACK-UP (.686, .580, .053)	1	
4	702B16	PISTON, HEAD	1	
5	P-216	RING, QUAD (.880, .674, .103)	1	
6	P-209	RING, BACK-UP (.864, .688, .088)	1	
7	P-654	O-RING (.879, .739, .070)	1	
8	P-112	O-RING (.504, .364, .070)	1	
9	P-848	O-RING (.941, .801, .070)	1	
10	702B17	CAP	1	
11	P-880	RING, RETAINING (NON-STANDARD)	1	
12	703A13	FITTING, DEFLECTOR	1	
13	530A16	DEFLECTOR, PIN	1	
14	P-572	STAT-O-SEAL (.430, .180, .125)	1	
15	P-573	SCREW, BUTTON HEAD SOC., 10-32 X 1/4	1	
702-053 SUB-ASSEMBLY, HANDLE				
16	P-838	O-RING (.568, .362, .103)**	2	
17	P-115	RING, BACK-UP (.551, .375, .088)	2	
18	P-727	O-RING (1.318, 1.112, .103)	1	
19	700B93	PLUG, PACKING	1	
20	P-893	O-RING (2.387, 2.109, .139)	1	
21	700A21	WASHER	1	
22	747-013	PISTON, AIR	1	
23	P-1387	WASHER, STEEL	1	
24	P-737	NUT, CONELOK, 1/4-20	1	
25	747-015	BASE, HANDLE	1	
26	P-894	O-RING (2.254, 2.114, .070)	1	
27	P-895	RING, RETAINING (INT. 0 2.440)	1	
28	P-1386	RING, RETAINING (EXT. 0 2.062)	1	
29	747-011	COVER, URETHANE BASE	1	
30	703A33	SUB-ASSEMBLY, TRIGGER	1	
31	P-223	O-RING (.285, .145, .070)	1	
32	747-018	HANDLE	1	
33	747-019	CYLINDER, POWER	1	
34	P-833	O-RING, DISOGRIN (1.068, .862, .103)	2	
35	P-919	RING, BACK-UP (.528, .422, .053)	1	
36	P-829	O-RING, DISOGRIN (.504, .364, .070)**	4	
37	747-017	PISTON, POWER	1	
38	700B73	SLEEVE, VALVE	1	
39	700A67	SPRING	1	
40	700A15	SUB-ASSEMBLY, VALVE SPOOL	1	
	41	700D15-2	SPOOL, VALVE***	1
	42	700A18	FILTER***	1
	43	700A69	SCREW, METERING***	1
44	P-834	O-RING (.816, .676, .070)**	2	
45	700A16	PLUG, VALVE	1	
46	700A17	MUFFLER	1	
47	P-279	RING, RETAINING (INT. 0.906)	1	
48	P-832	O-RING (.379, .239, .070)**	1	
49	702A22	GASKET	1	
50	P-27	SCREW, SOC. HD. CAP, 8/32 X 1/2	4	
51	670 037-1	ASSEMBLY, MANDREL CATCHER BAG*	1	
52	P-948	HOSE	1	
53	P-1505	PRE-SET IN-LINE PRESSURE REGULATOR	1	

*Not furnished with riveter; must be ordered separately if desired.

**No substitutions.

***These parts cannot be ordered separately, but must be ordered as a sub-assembly.

EXPLODED VIEW OF G702A

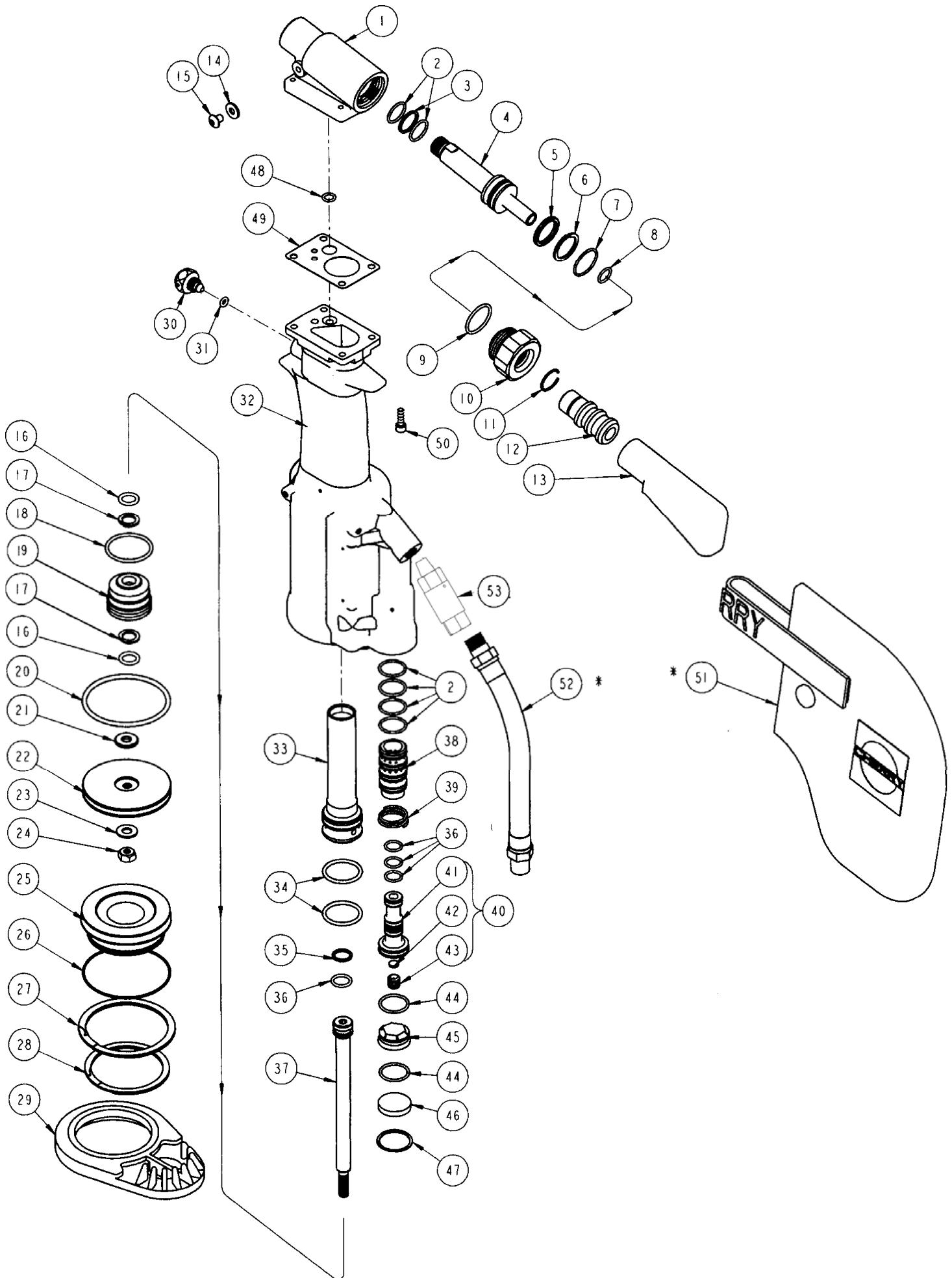



Declaration of Conformity

We, **Cherry Aerospace**

Located at **1224 East Warner Avenue, Santa Ana, CA 92705-0157, USA,**

In accordance with the provisions of

Machine Directive 2006/42/EC

Hereby declare under our sole responsibility that:

Equipment: Pneumatic Hydraulic Hand Riveter

Model Number: G-702A

Serial Number: _____

Is in conformity with the applicable requirements of the following standards:

EN ISO 12100:2010	Safety of Machinery; General Principles for design; Risk Assessment and Reduction
ISO/TR 14121-1&2:2007	Safety of Machinery, Risk assessment
EN 792-1:2000 + A1:2008	Safety requirements; Assembly power tools for non-threaded mechanical fasteners
ISO 8662-11	Hand-held portable power tools -- Measurement of vibrations at the handle
ISO 3744	Acoustics – Determination of sound power levels of noise sources
ISO 4413:2010.	Hydraulic fluid power - General Rules of safety
ISO 4414:2010.	Pneumatic fluid power - General Rules of safety

Signed by:  _____

Cris Cobzaru,
Master of Science in Mechanical Engineering
Sr. Technical Services / Installation Tooling Engineer

The Technical documentation for the machinery is available from:

Name: Karl-Heinz Beckers

Position: CE Representative and Western Europe Sales Manager

Address: Maternusstrasse 14, D-52538, Gangelt, Germany

Mobile Phone +49 -(0) 171 31 88020