

G-27 HAND RIVETER



CHERRY®
AEROSPACE

DESCRIPTION

The Cherry® G-27 Hand Riveter is designed specifically for the most efficient installation of 1/8" CherryMAX® Rivets.

This riveter is intended for use where the use of the Cherry® pneumatic riveters is not possible because of space constraints or unavailability of an air source.

DIMENSIONS (see picture)

Overall length of the G-27 is 9 1/4" the net weight is just 13 ounces and the pulling head is an integral part of the tool.

This compact, lightweight tool comes in a rugged plastic case.

OPERATION

Insert rivet stem into nosepiece.

Insert rivet into work with riveter nosepiece held firmly and squarely against head of rivet.

Maintain a steady pressure against rivet head and squeeze the handles to install the rivet. An additional stroke may be necessary depending on the rivet length and the thickness of the material being joined.

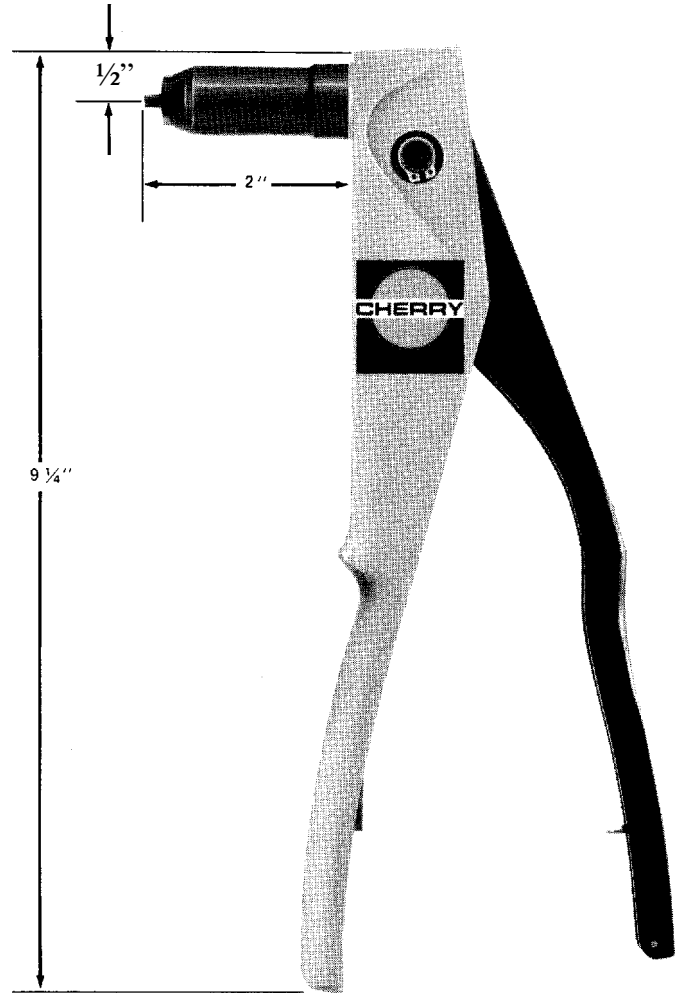

**PARTS LIST FOR
G-27 HAND RIVETER**

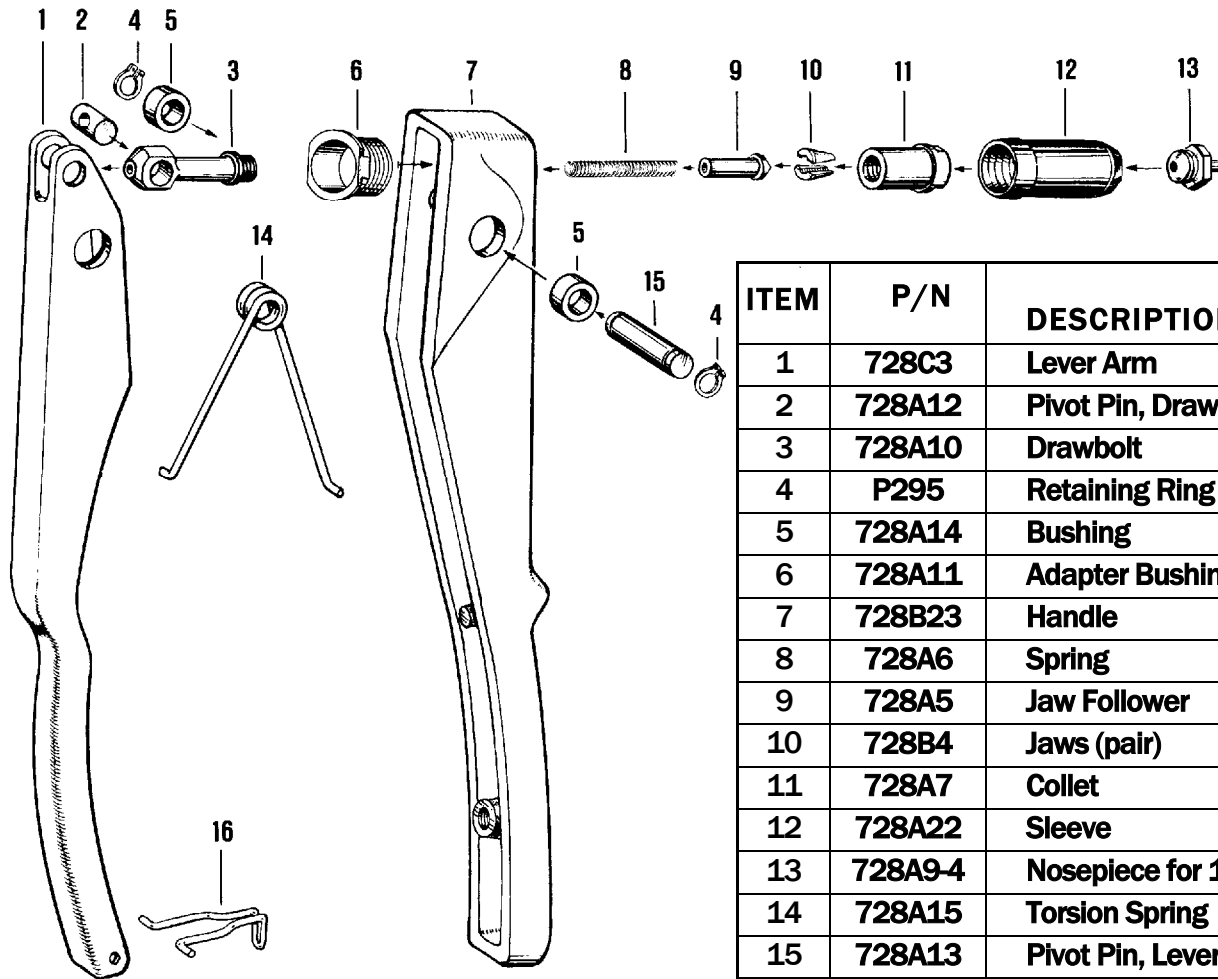

ITEM	P/N	DESCRIPTION	QTY
1	728C3	Lever Arm	1
2	728A12	Pivot Pin, Drawbolt	1
3	728A10	Drawbolt	1
4	P295	Retaining Ring	2
5	728A14	Bushing	2
6	728A11	Adapter Bushing	1
7	728B23	Handle	1
8	728A6	Spring	1
9	728A5	Jaw Follower	1
10	728B4	Jaws (pair)	1
11	728A7	Collet	1
12	728A22	Sleeve	1
13	728A9-4	Nosepiece for 1/8" rivets	1
14	728A15	Torsion Spring	1
15	728A13	Pivot Pin, Lever Arm	1
16	728A16	Clip	1

WARRANTY

Seller warrants the goods conform to applicable specifications and drawings and will be manufactured and inspected according to generally accepted practices of companies manufacturing industrial or aerospace fasteners. In the event of any breach of the foregoing warranty, Buyer's sole remedy shall be to return defective goods (after receiving authorization from Seller) for replacement or refund of the purchase price, at the Seller's option. Seller agrees to any freight costs in connection with the return of any defective goods, but any costs relating to removal of the defective or nonconforming goods or installation of replacement goods shall be Buyer's responsibility. SELLER'S WARRANTY DOES NOT APPLY WHEN ANY PHYSICAL OR CHEMICAL CHANGE IN THE FORM OF THE PRODUCT IS MADE BY BUYER.

THE FOREGOING EXPRESS WARRANTY AND REMEDY ARE EXCLUSIVE AND ARE IN LIEU OF ALL OTHER WARRANTIES AND REMEDIES; ANY IMPLIED WARRANTY AS TO QUALITY, FITNESS FOR PURPOSE, OR MERCHANTABILITY IS HEREBY SPECIFICALLY DISCLAIMED AND EXCLUDED BY SELLER. THIS WARRANTY IS VOID IF SELLER IS NOT NOTIFIED IN WRITING OF ANY REJECTION OF THE GOODS WITHIN ONE (1) YEAR AFTER INITIAL USE BY BUYER OF ANY POWER RIVETER OR NINETY (90) DAYS AFTER INITIAL USE OF ANY OTHER PRODUCT.

Seller shall not be liable under any circumstances for incidental, special or consequential damages arising in whole or in part from any breach by Seller, AND SUCH INCIDENTAL, SPECIAL, OR CONSEQUENTIAL DAMAGES ARE HEREBY EXPRESSLY EXCLUDED.

For more information please contact our Technical Services Department at Tel. 714-850-6022



CHERRY®
AEROSPACE

1224 East Warner Ave,
Santa Ana, Ca 92705
Tel: 1-714-545-5511
Fax: 1-714-850-6093
www.cherryaerospace.com