



PRINTED COPIES OF THIS DOCUMENT ARE FOR "REFERENCE" ONLY. CURRENT REVISIONS ARE AVAILABLE ONLINE.

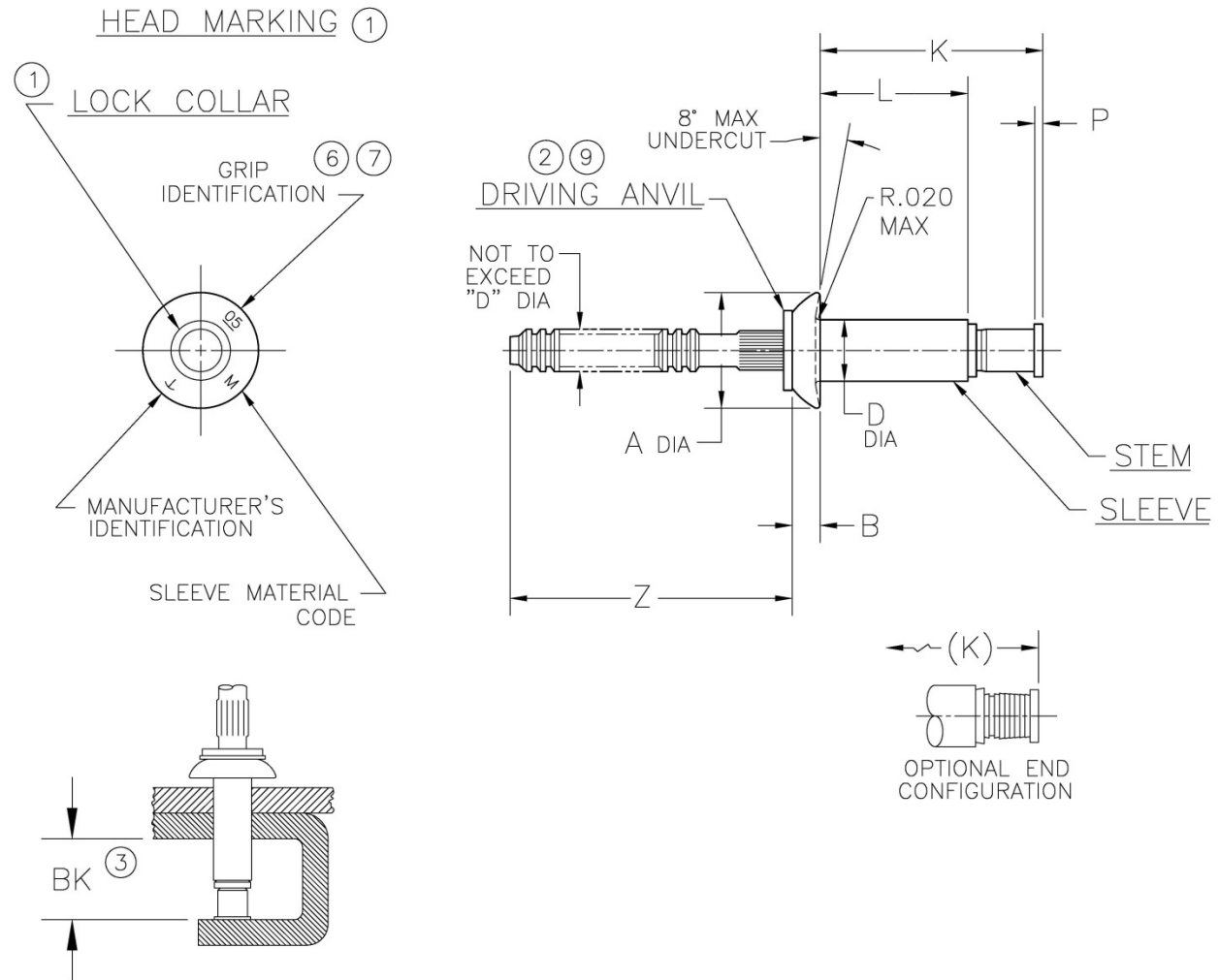

TABLE I

DIA. DASH NO.	A ±.010	B +.010 -.000	D +.003 -.001	P MIN	Z REF	③ BK MIN	HOLE LIMITS	
							MIN	MAX
-4	.250	.054	.140	.010	.87	.390	.143	.146
-5	.312	.067	.173	.015	.94	.395	.176	.180
-6	.375	.080	.201			.410	.205	.209
-8	.500	.107	.267			.490	.271	.275

NOTICE: ALL DIMENSIONS ARE IN INCHES AND APPLY AFTER FINISH AND BEFORE LUBRICATION UNLESS OTHERWISE SPECIFIED.

WARNING: FASTENERS MAY NOT PERFORM PROPERLY IF ALTERED FROM THE MANUFACTURER'S AS-SHIPPED CONDITION OR INSTALLED IN CONDITIONS OTHER THAN SPECIFIED HEREIN.

PROCUREMENT SPECIFICATION: PS-CMR-3000	CHERRYMAX ® RIVET UNIVERSAL HEAD OVERSIZE DIAMETER	SHEET 1 OF 4		PART NUMBER
NAS 523 CODE: SEE TABLE II		ISSUE	06-24-92	CR3553
		REV.	AG 31 JAN 19	



TABLE II

FINISH CODE	NAS523 CODE	MATERIAL ⑤			FINISH		
		SLEEVE	STEM	LOCK COLLAR	SLEEVE	STEM	LOCK COLLAR
---	AZA	MONEL PER QQ-N-281	15-7 PH CRES PER AMS 5657	A-286 CRES PER AMS 5731 & AMS 5737	NONE	NONE	PASSIVATE PER AMS 2700
DL ⑨	---					PASSIVATE PER AMS 2700 & DICRONITE DL-5	
EE	---				ALUM COAT PER NAS4006 & BMS1085	NONE	
P	AZB				ALUM COAT PER MIL-DTL-83488		
PR ⑧	---				NONE	LUBECO 905	
Y	---				ALUM COAT PER NAS4006 CLASS NC	NONE	
GEE ⑪	---				ALUM COAT PER MIL-DTL-83488 CL 3, TYPE II (SUPPLEMENTAL: MIL-DTL-5541 CL 1A, TYPE II)		
GP ⑪	---						

SHEET 2 OF 4		PART NUMBER
ISSUE	06-24-92	CR3553
REV.	AG 31 JAN 19	



TABLE III

GRIP DASH NO.	GRIP RANGE		-4 DIA		-5 DIA		-6 DIA		-8 DIA	
	MIN	MAX	L +.000 -.030	K MAX	L +.000 -.030	K MAX	L +.000 -.030	K MAX	L +.000 -.030	K MAX
-01	④	.062	.175	.37	.203	.43	.242	.45	---	---
-02	.063	.125	.238	.46	.246	.47	.265	.50	.313	.57
-03	.126	.187	.301	.52	.309	.53	.328	.55	.375	.64
-04	.188	.250	.363	.58	.371	.60	.390	.62	.437	.70
-05	.251	.312	.426	.65	.434	.66	.453	.68	.500	.77
-06	.313	.375	.488	.71	.496	.72	.515	.74	.562	.83
-07	.376	.437	.551	.78	.559	.79	.578	.82	.625	.89
-08	.438	.500	.613	.84	.621	.85	.640	.89	.687	.95
-09	.501	.562	.676	.90	.684	.91	.703	.95	.750	1.02
-10	.563	.625	---	---	.746	.98	.765	1.01	.812	1.08
-11	.626	.687	---	---	.809	1.04	.828	1.07	.875	1.14
-12	.688	.750	---	---	---	---	.890	1.14	.937	1.20

NOTES:

- ① HEAD MARKINGS AND LOCK COLLAR VISIBLE AFTER INSTALLATION.
- ② SILVER COLORED DRIVING ANVIL IDENTIFIES OVERSIZE DIAMETER RIVETS.
- ③ MINIMUM BLIND SIDE CLEARANCE FOR SATISFACTORY INSTALLATION. INSPECTION OF THIS FEATURE IS NOT PERFORMED BY THE MANUFACTURER.
- ④ MINIMUM GRIP FOR -4 DIA IS .025; FOR -5 IS .031; AND FOR -6 IS .037.
- ⑤ MATERIAL DESIGNATION REFERS TO CHEMICAL COMPOSITION ONLY.
- ⑥ SINGLE DIGIT HEAD MARKING IS PERMISSBLE, AT MANUFACTURER’S OPTION, FOR GRIP DASH NUMBER LESS THAN 10.
- ⑦ A DASH MAY BE MARKED UNDER OR TO THE RIGHT SIDE OF THE GRIP IDENTIFICATION AT MANUFACTURER’S OPTION.
- ⑧ “PR” CODE – PARTS ARE MANUFACTURED BARE; IF LUBE IS REQUIRED, USE PAR 90 ONLY. IN ADDITION, MANUFACTURER’S OPTIONS TO APPLY MOLYBDENUM DISULFIDE TYPE 1 PER AS 5272, TO STEM ONLY.
- ⑨ “DL” FINISH CODE PARTS HAVE NICKEL-PLATED DRIVING ANVILS. LUBRICANTS OTHER THAN DICRONITE DL-5 MAY NOT BE USED. “DL” FINISH MEETS SPECIFICATION DOD-L-85645.
- ⑩ FINISH CODES MAY BE COMBINED. EXAMPLE: CODE “PPR” = ALUMINUM COATED SLEEVE WITH “PR” LUBE RESTRICTION. WHEN COMBINING FINISH CODES, PLACE PLATING CODE BEFORE LUBE CODE.
- ⑪ FINISH CODES WITH THE PREFIX “G” INDICATE REACH COMPLIANT COATING.

SHEET 3 OF 4			PART NUMBER
ISSUE	06-24-92		CR3553
REV.	AG	31 JAN 19	



EXAMPLE OF CHERRY PART NUMBER:

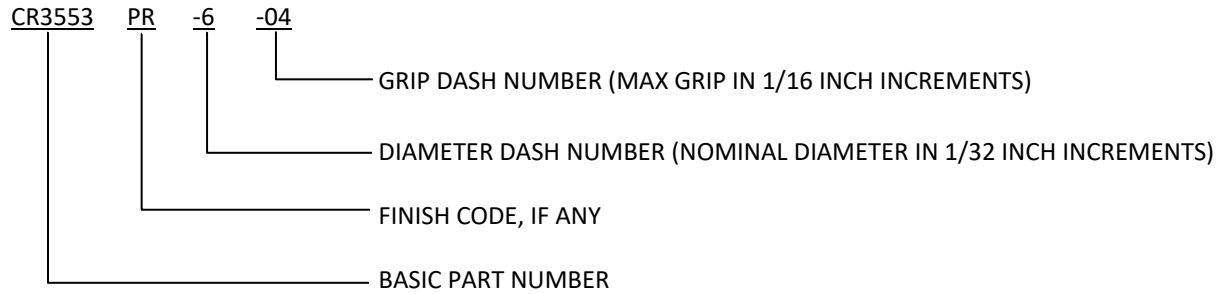

SHEET 4 OF 4		PART NUMBER
ISSUE	06-24-92	CR3553
REV.	AG 31 JAN 19	

STANDARDS PAGE REVISION LOG

REV LTR	DATE	DCR NUMBER	REVISION DESCRIPTION	COMP. BY
AG	31 JAN 19	19-0052	<ul style="list-style-type: none">SHEET 1 – ADDED NOTE ③ TO BK MINSHEET 2 – ADDITIONAL COMMENT ADDED TO NOTE ③	AD