

# CHERRY® HOLLOW END E-Z BUCK®

40KSI SHEAR STRENGTH  
COLUMBIUM/TITANIUM  
ONE PIECE FASTENER FOR DOUBLE FLUSH  
SECURING OF COMPOSITE STRUCTURES



**CHERRY®**  
**AEROSPACE**  
*SPS Fastener Division, a PCC Company*

# CHERRY® HOLLOW END E-Z BUCK®

## 40KSI SHEAR STRENGTH COLUMBIUM/TITANIUM ONE PIECE FASTENER FOR DOUBLE FLUSH SECURING OF COMPOSITE STRUCTURES

### CONTENTS

Features and Specifications .....	1
Standards .....	2
Hole Preparation .....	3
Grip Selection .....	4
Installation .....	5
Inspection .....	5

### LIMITED WARRANTY

Seller warrants the goods conform to applicable specifications and drawings and will be manufactured and inspected according to generally accepted practices of companies manufacturing industrial or aerospace fasteners. In the event of any breach of the foregoing warranty, Buyer's sole remedy shall be to return defective goods (after receiving authorization from Seller) for replacement or refund of the purchase price, at the Seller's option. Seller agrees to any freight costs in connection with the return of any defective goods, but any costs relating to removal of the defective or nonconforming goods or installation of replacement goods shall be Buyer's responsibility. SELLER'S WARRANTY DOES NOT APPLY WHEN ANY PHYSICAL OR CHEMICAL CHANGE IN THE FORM OF THE PRODUCT IS MADE BY BUYER. THE FOREGOING EXPRESS WARRANTY AND REMEDY ARE EXCLUSIVE AND ARE IN LIEU OF ALL OTHER WARRANTIES AND REMEDIES; ANY IMPLIED WARRANTY AS TO QUALITY, FITNESS FOR PURPOSE, OR MERCHANTABILITY IS HEREBY SPECIFICALLY DISCLAIMED AND EXCLUDED BY SELLER. This warranty is void if seller is not notified in writing of any rejection of the goods within one (1) Year after initial use by buyer of any power Riveter or ninety (90) days after initial use of any other product. Seller shall not be liable under any circumstances for incidental, special or consequential damages arising in whole or in part from any breach by Seller, AND SUCH INCIDENTAL, SPECIAL, OR CONSEQUENTIAL DAMAGES ARE HEREBY EXPRESSLY EXCLUDED.

Our policy is one of continuous development. Specifications shown in this document may be subject to changes introduced after publication.

E-Z Buck® is a trademark of Cherry Aerospace.

### NOTE

The properties, strengths, dimensions, installed characteristics and all other information in this catalog is for guidance only to aid in the correct selection of the products described herein and is not intended or implied as part of the warranty. All applications should be evaluated for functional suitability and available samples of the described parts can be requested for installed tests, suitability and evaluations.

# CHERRY® HOLLOW END E-Z BUCK®

## FEATURES AND SPECIFICATIONS

The Cherry Hollow End E-Z Buck is a 40KSI shear Titanium/ Columbium alloy rivet with a unique patented recess configuration designed specifically for double-flush applications in composite and metallic materials. Teamed with its specially designed installation tool, Cherry Hollow End E-Z Buck offers a number of significant advantages:

**Multiple usage** — The Cherry Hollow End E-Z Buck meets all double flush requirements on flaps, aileron close out and trailing edge applications.

**Low installation loads** — Less than half the force required to install a solid rivet of the same material.

**Uniform structural loading** — The installation tool provides for even distribution of the load on the structure, thereby minimizing potential damage to the composite materials.

**Built-in resistance to damage** — When installed with a properly sized squeeze tool, the rivet/tool combination actually prevents over squeezing.

**Mechanical properties** — Contact Cherry Technical Services for information regarding Cherry Hollow End E-Z Buck mechanical properties.

## NUMBERING SYSTEM

Cherry Part Number Example:

**CSR90433 -5 F -8**

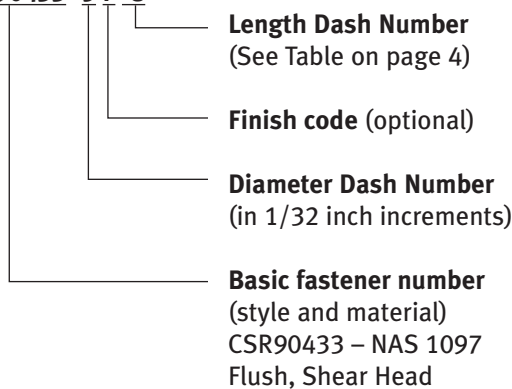

## POUNDS PER 1000 PIECES

Grip Dash No.	Rivet Diameter 1/8	Rivet Diameter 5/32	Rivet Diameter 3/16
-4	.338	—	—
-5	.420	.674	1.017
-6	.505	.800	1.197
-7	.590	.930	1.380
-8	.680	1.060	1.570
-9	.760	1.190	1.750
-10	.840	1.320	1.940
-11	.930	1.450	2.120
-12	1.010	1.580	2.310
-13	1.100	1.710	2.490
-14	1.180	1.830	2.680
-15	1.265	1.960	2.860
-16	1.350	2.090	3.050
-17	1.430	2.220	3.230
-18	1.520	2.350	3.410
-19	1.600	2.480	3.600
-20	1.690	2.610	3.780
-21	1.770	2.740	3.970
-22	1.860	2.870	4.150
-23	1.940	2.990	4.340
-24	2.020	3.120	4.520
-25	2.110	3.250	4.710
-26	2.190	3.380	4.890
-27	2.280	3.510	5.080
-28	2.360	3.640	5.260
-29	2.450	3.770	5.450
-30	2.530	3.900	5.630
-31	2.620	4.030	5.820
-32	2.700	4.155	6.000

# CHERRY® HOLLOW END E-Z BUCK®

## STANDARDS

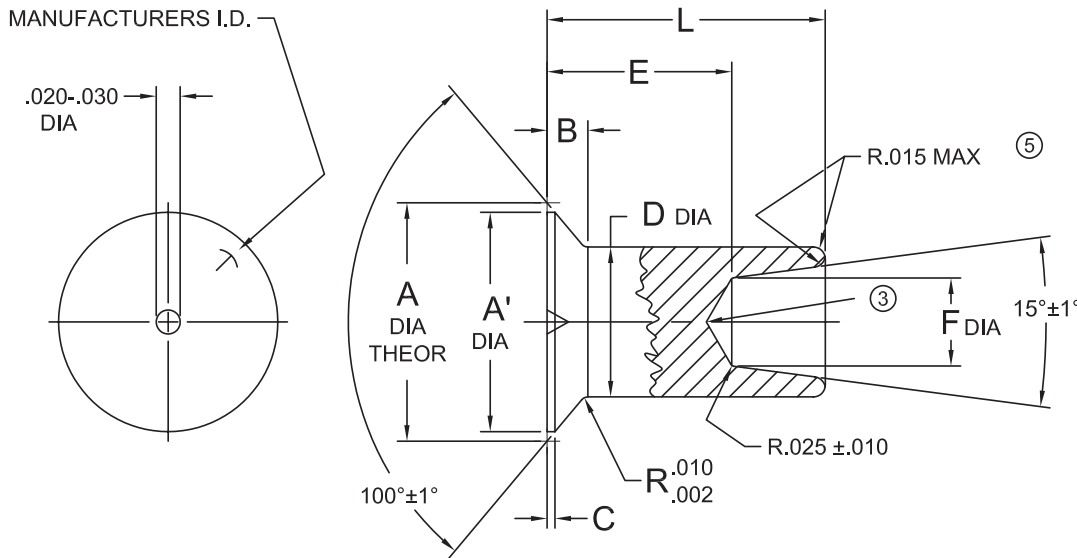

Diameter Dash No.	A ±.004	A' Min	B Ref	C Max	D +.003 -.001	F +.005 -.000
-4	.192	.174	.028	.006	.125	.073
-5	.243	.225	.037	.008	.156	.091
-6	.298	.275	.046	.010	.187	.110
-7 ⑧	.324	.298	.046	.010	.219	.142

### Notes:

1. A .001" increase in "D" diameter is permissible within .100" from the base of the head.
2. Conical surface of head and tail recess to be concentric to "D" diameter within .005" F.I.M.
- ③ Bottom configuration of recess is optional.
4. Head cocking angle relative to rivet axis is 1/2° maximum.
- ⑤ Free flow of material in this area may be round, flat or chamfered.
6. Tail recess configuration is covered under Boeing Patent #4,221,041 and license agreement between Cherry Aerospace and the Boeing Company.
7. This rivet must be installed with Cherry tool 839B1-(x) or 839B10-(x). Use of tool 839B3 or 839B13 to maintain centering is optional.
- ⑧ -7 Diameter is for replacement/repair for -6 diameter. Not to be used for new design.
9. Dimensions apply after plating and coating, but are exclusive of lubrication.
10. Localized underfill on end of rivet not to exceed .005" below minimum length.
11. For L and E dimensions, see Table on page 4.

**Material:** 55 Ti-4 5Cb Titanium alloy chemical composition per AMS 4982. Hydrogen content of finished product to be 85 ppm maximum.

**Heat Treat:** Annealed

**Finish:**

- No code letter — none
- Code letter "E" — Aluminum coating per NAS 4006
- Code letter "F" — Phosphate fluoride per BAC 5861
- Code letter "G" — I.V.D. Aluminum coating per MIL-DTL-83488, Class 3, Type II
- Code letter "W" — Anodize blue per ISO 8080

**Lubrication:** None

# CHERRY® HOLLOW END E-Z BUCK®

## HOLE PREPARATION

Holes should be prepared in accordance with User procedure. If differences exist between this brochure and any User document, contact your engineering department for clarification. The following items outline "typical" practice for producing holes in composite materials.

1. Components should be firmly clamped together so there is no gap between the components at the hole location during hole preparation.
2. Fastener holes and countersinks should be perpendicular within 2° to the surface against which the shop formed head will bear.
3. Lubricants approved by your engineering department for the material being drilled may be used.
4. Suitable back-up must be provided so as to preclude drill damage to the composite structure.
5. Facing surfaces should be free from all foreign materials, except sealant or finishes, as allowed by engineering drawing.
6. Graphite particles resulting from hole preparation should be vacuumed from the structure.
7. Surface protection requirements for holes, countersinks, fastener installation and sealing should be in accordance with the engineering drawing.
8. Only drills recommended for use in composite materials should be used.

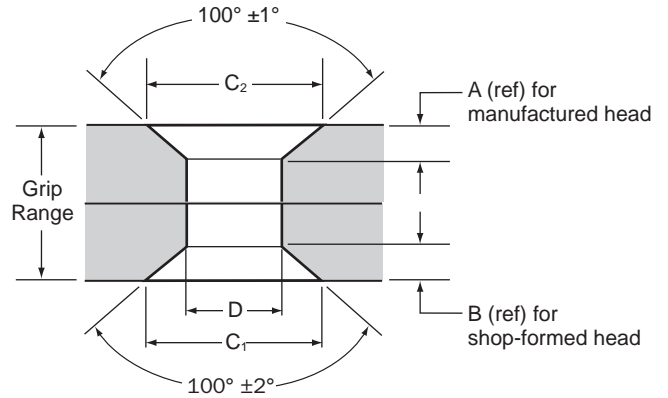

RIVET DIAMETER	A REF	CSR90433			
		B REF	C1 DIA	C2 DIA	D DIA
1/8 (-4)	.028	.028	.195 .189	.195 .189	.132 .129
5/32 (-5)	.037	.037	.247 .242	.247 .242	.162 .159
3/16 (-6)	.046	.046	.302 .297	.302 .297	.195 .191
*7/32 (-7)	.046	.046	.328 .323	.328 .323	.227 .224

\* See note © on page 2.

# CHERRY® HOLLOW END E-Z BUCK®

## GRIP SELECTION

Measure material thickness at hole location, as shown opposite, using a suitable measuring device.

NOTE: Extreme care must be exercised in selecting the fastener grip length. Variations in material thickness, sealant application, gaps, etc., can cause a change in grip.

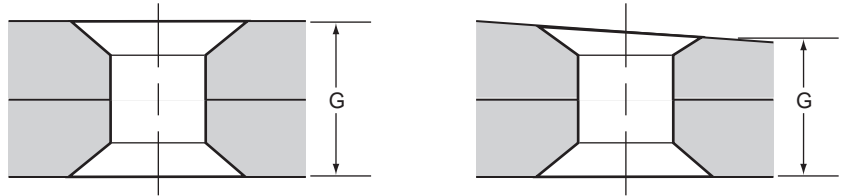

Compare measurements to "Grip Range" in chart below to select proper rivet grip. (See the last dash number in the part number.)

LENGTH DASH NO.	GRIP RANGE		-4 DIA		-5 DIA		-6 DIA		-7 DIA*	
			L	E	L	E	L	E	L	E
	MIN	MAX	±.005	±.005	±.005	±.005	±.005	±.005	±.005	±.005
-4	.095	.125	.149	.061	—	—	—	—	—	—
-5	.126	.156	.180	.092	.186	.084	.192	.075	—	—
-6	.157	.187	.212	.124	.218	.116	.223	.106	.223	.106
-7	.188	.219	.243	.155	.249	.147	.255	.138	.255	.138
-8	.220	.250	.274	.186	.280	.178	.286	.169	.286	.169
-9	.251	.281	.305	.217	.311	.209	.317	.200	.317	.200
-10	.282	.312	.337	.249	.343	.241	.348	.231	.348	.231
-11	.313	.343	.369	.280	.374	.272	.379	.262	.379	.262
-12	.344	.375	.399	.311	.405	.303	.411	.294	.411	.294
-13	.376	.407	.430	.342	.436	.334	.442	.325	.442	.325
-14	.408	.438	.462	.374	.468	.366	.474	.357	.474	.357
-15	.439	.469	.493	.405	.499	.397	.505	.388	.505	.388
-16	.470	.500	.524	.436	.530	.428	.536	.419	.536	.419
-17	.501	.531	.555	.467	.561	.459	.567	.450	.567	.450
-18	.532	.562	.587	.499	.593	.491	.598	.481	.598	.481
-19	.563	.594	.618	.530	.624	.522	.630	.513	.630	.513
-20	.595	.625	.649	.561	.655	.553	.661	.544	.661	.544
-21	.626	.656	.680	.592	.686	.584	.692	.575	.692	.575
-22	.657	.687	.712	.624	.718	.616	.723	.606	.723	.606
-23	.688	.719	.743	.655	.749	.647	.755	.638	.755	.638
-24	.720	.750	.774	.686	.780	.678	.786	.669	.786	.669
-25	.751	.781	.805	.717	.811	.709	.817	.700	.817	.700
-26	.782	.812	.837	.749	.843	.741	.848	.731	.848	.731
-27	.813	.843	.868	.780	.874	.772	.879	.762	.879	.762
-28	.844	.875	.899	.811	.905	.803	.911	.794	.911	.794
-29	.876	.907	.930	.842	.936	.834	.942	.825	.942	.825
-30	.908	.938	.962	.874	.968	.866	.974	.857	.974	.857
-31	.939	.969	.993	.905	.999	.897	1.005	.888	1.005	.888
-32	.970	1.000	1.024	.936	1.030	.928	1.036	.919	1.036	.919

\*7/32" (-7) diameter is for replacement/repair of 3/16" (-6) diameter only. Not to be used for new design.

# CHERRY® HOLLOW END E-Z BUCK®

## INSTALLATION & INSPECTION



### INSTALLATION

Cherry Hollow End E-Z Buck® should be installed with automatic riveting machines or by a squeezer of sufficient size to provide the upset loads listed below.

The Installation Snap Dies are designed to center the squeezer on the rivet and prevent damage to the structure. Be sure the die center pin is in the rivet center dimple before actuating the squeezer.

Loads required to provide an acceptable upset are shown below. Loads deviating from these values should be questioned, but are acceptable if all inspection requirements shown below are met.

Hollow End E-Z Buck Nominal Diameter	Upset Load (Lb) ±200 Lb
1/8" (-4)	2500
5/32" (-5)	2700
3/16" (-6)	3000
*7/32" (-7)	3750

\*See note ⑦ on page 2.

### Cherry Flaring Snap Die Part Numbers

Rivet Diameter	3/16" Diameter Mount	1/4" Diameter Mount
1/8"	839B1-4	839B10-4
5/32"	839B1-5	839B10-5
3/16"	839B1-6	839B10-6
7/32"	839B1-7	839B10-7

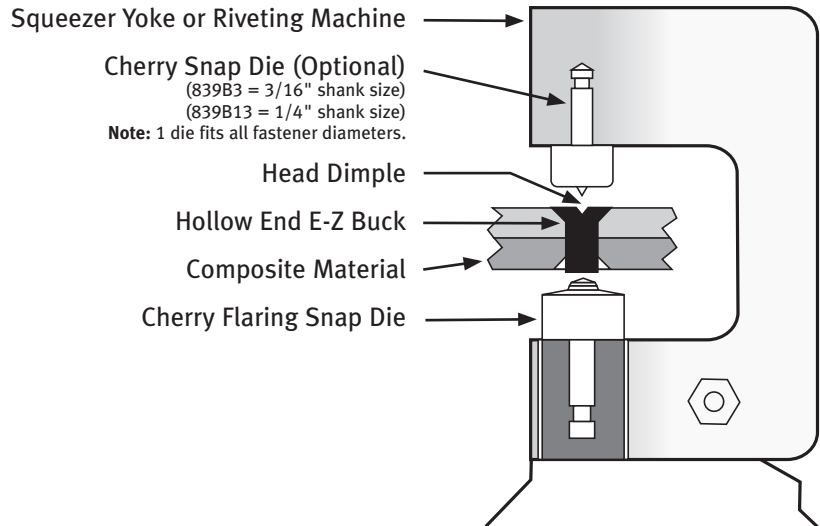

### INSPECTION

#### NOTES:

1. Rivet flushness shall be within the limits shown.
2. Rivets may be shaved to bring both surfaces within the flushness requirements with the following restriction: The head height of the manufactured head side may not be reduced more than .005" by shaving.
3. Cracks in the flared head are unacceptable.
4. Composite structure shall show no marring or signs of damage around the flared end of the fastener.

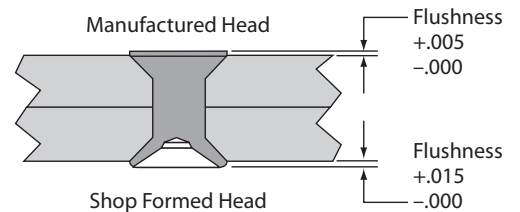

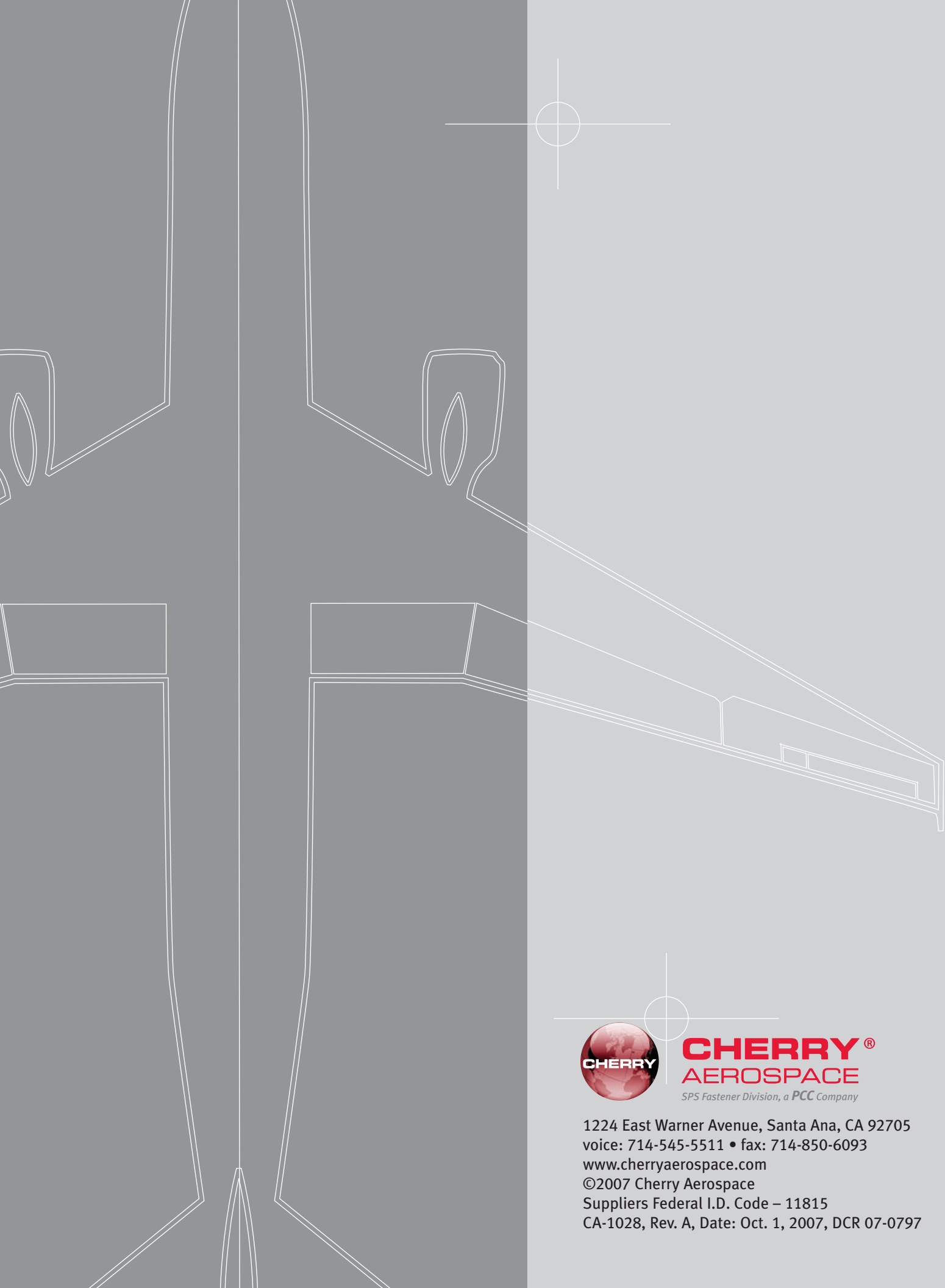

**CHERRY<sup>®</sup>**  
**AEROSPACE**

*SPS Fastener Division, a PCC Company*

1224 East Warner Avenue, Santa Ana, CA 92705

voice: 714-545-5511 • fax: 714-850-6093

[www.cherryaerospace.com](http://www.cherryaerospace.com)

©2007 Cherry Aerospace

Suppliers Federal I.D. Code – 11815

CA-1028, Rev. A, Date: Oct. 1, 2007, DCR 07-0797